

JULY 2020

MARITIME REPORTER AND ENGINEERING NEWS

marinelink.com

SHRINKING COSTS,
ADVANCING TECH DRIVE

OFFSHORE WIND

Since 1939

Number 7 Volume 82



GET ON BOARD

WITH OPEN SEAWATER LUBRICATED PROPELLER SHAFTS

PROVEN PERFORMANCE:

550+ commercial ships are using

Thordon COMPAC bearings

SUBSTANTIALLY LOWER OPERATIONAL COST:

Compared to a sealed oil system

FUTURE COMPLIANT

Meets VGP & Polar Code Regulations

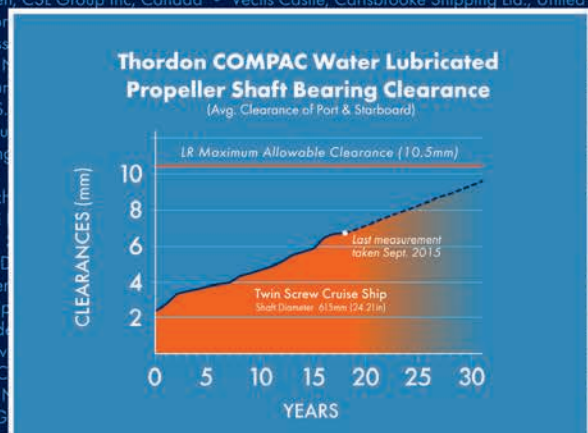

To learn more visit us online at thordonbearings.com/provenperformance

Specify an Open Thordon COMPAC Seawater Lubricated Propeller Shaft Bearing System for your newbuild

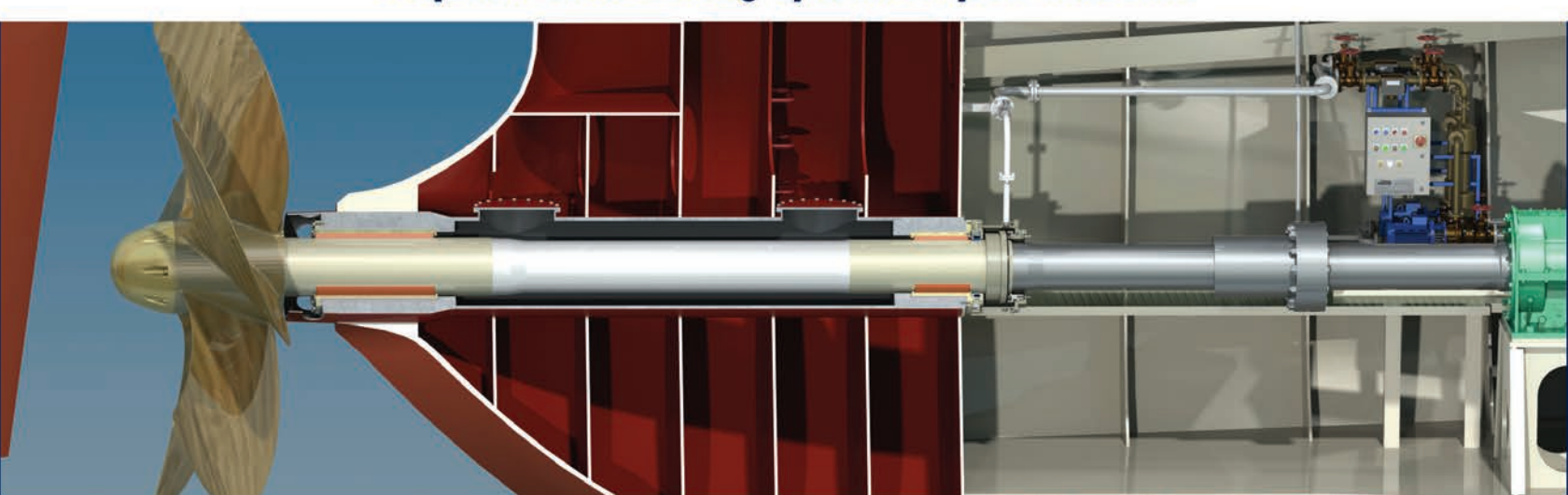

THORDON
THORDON BEARINGS INC.

ZERO POLLUTION | HIGH PERFORMANCE | BEARING & SEAL SYSTEMS

For more information contact Thordon or your local authorized Thordon distributor at www.ThordonBearings.com



SMM

smm-hamburg.com /trailer

the leading international
maritime trade fair

driving the maritime transition

2 - 5 feb 2021
hamburg

SMM fuels change in the maritime industry by bringing together its most influential players and presenting solutions that make shipping greener, smarter and safer. Be part of it and see what's technologically possible, connect with peers and get fresh impetus for your business:

- 2,200+ exhibitors from the entire maritime value chain
- 50,000 industry professionals from 120+ countries
- Top-notch conferences and first-class networking events

SMM
rescheduled for
2 - 5 feb 2021
save the date

Hamburg
Messe + Congress



smm-hamburg.com/news



[linkedin.com/company/smmfair](https://www.linkedin.com/company/smmfair)



twitter.com/SMMfair
#SMMfair



[facebook.com/SMMfair](https://www.facebook.com/SMMfair)



[youtube.com/SMMfair](https://www.youtube.com/SMMfair)



42

Photo: Ørsted

Features

- 16 Profiles in Training: Marcus Cheesman**
The founder of Seven Seas Preparatory Academy started his maritime training at the age of thirteen.
By Greg Trauthwein
-
- 28 Cruise Dreams: Plotting the Return**
While many businesses have been interrupted, COVID-19 has shuttered the cruise market. Captain Harvard Ramsøy, VP, Marine Operations & Safety @Genting Cruise Lines, discusses the path back.
By Greg Trauthwein
-
- 32 Power Play: WinGD Debuts X-DF2.0**
WinGD says its new dual fuel two-stroke technology can reduce methane slip emissions up to 50 percent.
By Greg Trauthwein
-
- 36 Understanding Autonomy**
All technology comes with risk and reward, and autonomous ship solutions are no exception.
By Jake Gerlach, PE
-
- 42 A Trillion \$ Market in the Making**
A new study from World Energy Reports projects the offshore wind market is on pace to become a trillion dollar business.
By Eric Haun

Departments

- 6 Editorial
8 By the Numbers
9 “Quotable”
10 Leading Off
12 Government Update
Shame on Port States
14 Training Tips for Ships
Dredging & Using Data
20 Leadership Training
22 Communication
24 Ship Emissions
The Path to Zero
26 Offshore Wind
30 Interview *George Whittier, CEO, Fairbanks Morse*
46 Tech Files *Bearings*
48 Tech Files *Ventilation*
50 Tech Files *New Products*
52 Software Solutions
54 In the Shipyard
56 The Final Word *Battery Fires*
59 Buyer’s Directory
60 Classifieds
64 Advertising Index

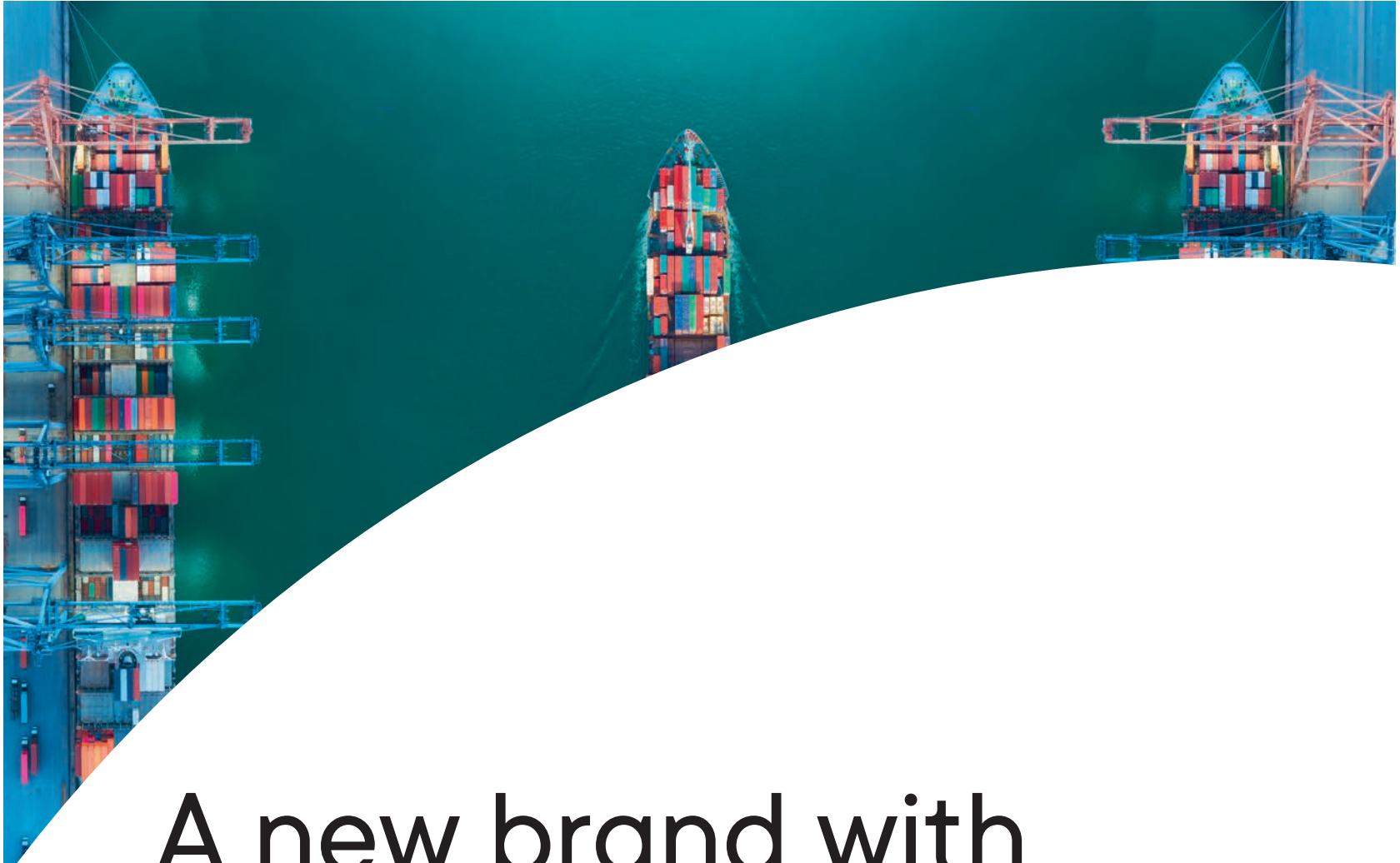

A new brand with **long tradition** enters the stage. PBST.

We are your dependable partner for holistic,
advanced and inspiring air-management
systems.

↗ More information:
air-management@pbst.eu
www.pbst.eu

**PB
ST**

Authors



Bonvento



Bryant



Clark



Cox



Delucia



Ewing



Fisch



Gerlach



Goldberg



Mulligan



Plevrakis



van Hemmen

Bonvento

Matthew Bonvento an Assistant Professor of Nautical Science. Previously he served as Senior Manager for Safety, Security, Regulatory, and Quality Compliance for Vanuatu Maritime Services.

Bryant

Dennis Bryant is with Bryant's Maritime Consulting, and a regular contributor to Maritime Reporter & Engineering News.

Clark

David Clark is CM Labs Senior Product Marketing Manager. A graduate of Concordia University (Montreal), he has two decades of experience in the high-tech sector.

Captain Cox

Captain John Cox is the CEO of Safety Operating Systems. He is a 50-year aviation veteran with experience as a corporate pilot, airline pilot, instructor, test pilot and safety professional. For the last 10 years he has been the aviation analyst for NBC, MSNBC, CNBC and the Weather Channel.

Delucia

Sandro Delucia is the Commercial Maritime Product Director at Speedcast. He is engaged in driving Speedcast's standard and bespoke solutions with an emphasis on Crew, Operational and onboard VM service.

Ewing

Tom Ewing specializrd in energy and environmental topics.

Fischer

Lars Fischer is Managing Director of Softship Data Processing Ltd, Singapore, a wholly owned subsidiary of Softship AG, the leading provider of software solutions to the international liner shipping sector. Softship is part of the WiseTech Global group.

Gerlach

Jake Gerlach is a professional Marine Engineer at marine consulting firm Glostén. His project work focuses on mechanical and control system integration, especially for remote control and autonomous projects. Before Jake joined Glostén, he spent 10 years as a submarine officer.

Goldberg

Murray Goldberg is CEO of Marine Learning Systems, maker of MarineLMS.

Mulligan

Tom Mulligan was born in London in 1958 and grew up in Manchester, England. He graduated Trinity College Dublin in 1979 with a BA Hons Degree in Natural Sciences (Chemistry). Following a period as a production chemist in an electronic circuit board manufacturing company, he returned to the University of Limerick in 1986 where he obtained a Masters Degree in Industrial Chemistry in 1988. Today, based in Ireland, he serves as Maritime Reporter & Engineering News' science and technology writer.

Plevrakis

Georgios Plevrakis is the Director of Global Sustainability for ABS.

van Hemmen

Rik van Hemmen is the President of Martin & Ottaway, a marine consulting firm that specializes in the resolution of technical, operational and financial issues in maritime.

MARITIME REPORTER AND ENGINEERING NEWS

MARINELINK.COM

ISSN-0025-3448
USPS-016-750
No. 7 Vol. 82

Maritime Reporter/Engineering News (ISSN # 0025-3448) is published monthly (twelve issues) by Maritime Activity Reports, Inc., 118 East 25th St., New York, NY 10010-1062. Periodicals Postage Paid at New York, NY and additional mailing offices.

POSTMASTER:

Send all UAA to CFS. NON-POSTAL AND MILITARY FACILITIES send address corrections to Maritime Reporter, 850 Montauk Hwy., #867, Bayport, NY 11705.

The publisher assumes no responsibility for any misprints or claims or actions taken by advertisers. The publisher reserves the right to refuse any advertising. Contents of the publication either in whole or part may not be produced without the express permission of the publisher.

Copyright © 2020 Maritime Activity Reports, Inc.

SUBSCRIPTION INFORMATION

In U.S.:

One full year (12 issues) \$110.00;
Two years (24 issues) \$190.00

Rest of the World:

One full year (12 issues) \$189.00;
two years \$228.00 (24 issues)
including postage and handling.

CONTACT INFORMATION:

Email: mrcirc@marinelink.com
Web: www.marinelink.com
t: (212) 477-6700
f: (212) 254-6271



Business Publications Audit
of Circulation, Inc.

THE FUTURE OF OFFSHORE TECHNOLOGY TODAY

Connecting a global market of customers and suppliers with cutting edge offshore energy technology is *Offshore Engineer Magazine's* sweet spot. With our proven readership, we will deliver the right audience for your media budget.



Learn more at
OEDIGITAL.COM



THE FUTURE OF OFFSHORE ENERGY & TECHNOLOGY.



As we enter the dog days of summer, this is a period in maritime when things slow down as people traditionally take summer vacations in July and August. Without overstating the obvious, though, this is an odd year. Don't get me wrong, 'slow' is the operative term across many sectors of maritime, as the disruption in business – the disruption in life – has left far more questions than answers. Case in point is the recreational boat market. Just as the world was sliding to a halt in early March, I sold my boat with the aim of upgrading to something a bit larger to accommodate longer trips and longer stays out and about on the east coast. Then, some boats we were eyeing in Connecticut and Rhode Island became inaccessible due to travel restrictions, so I decided to put the search on hold figuring the boat market would soften with economic uncertainty. *I was dead wrong!*

The recreational boat market is booming, as people put travel plans on hold, reverting to the 'stay-cation.' At the same time, from what I hear, boat builders are not ramping up production, lest they get burned when the market inevitably softens. Predicting market direction in the best of times is fraught with risk; predicting market direction in today's time is a roll of the dice without solid research behind it.

That said, one emerging opportunity that has kept some momentum is Offshore Wind Energy. Traditional offshore oil and gas markets remain in the doldrums, and the rapidity with which offshore renewable energy is picking up speed is notable.

Cover Image:

Photo: Jan De Nul

This month **Eric Haun** reports on a new study from World Energy Reports' (WER), the *Outlook for Offshore Wind Power: The Frontier of Future Energy* released last month. Haun's report starts on page 42, and while I don't want to steal his thunder, the findings are impressive:

- WER expects **16 GW of additional offshore capacity** to be added in 2020-2021, driven by mature markets in Northern Europe and fast-emerging markets in China;
- WER identifies some **500 GW of projects and development zones** in the planning and development stages, mainly coming from Europe, Asia and the U.S.
- WER identifies floating offshore wind turbines as the future, as floating solutions will enable wind farm construction in deeper waters that hold some 80% of the world's wind capacity potential. **A pipeline of more than 50 GW of floating capacity requiring \$93 billion to \$148 billion of capex investment has been identified.**
- Everyone likes a big number, and WER delivers, projecting offshore wind projects will require between **\$1 trillion and \$1.5 trillion of capex over the next two decades.**

If even a fraction of the projections come to fruition, advances in the offshore wind sector, particularly off the east coast U.S., could effectively energize the offshore energy, maritime, port and logistics market for a generation to come.

Gregory R. Trauthwein
Editor & Associate Publisher
trauthwein@marinelink.com

MARITIME REPORTER AND ENGINEERING NEWS

MARINELINK.COM

HQ
118 E. 25th St., 2nd Floor
New York, NY 10010 USA
T +1 212 477 6700; F +1 212 254 6271

FL Office
215 NW 3rd St
Boynton Beach, FL 33435-4009
T +1 561 732 4368; F +1 561 732 6984

Publisher
John C. O'Malley
jomalley@marinelink.com

Associate Publisher/Editorial Director
Greg Trauthwein
trauthwein@marinelink.com

Vice President, Sales
Rob Howard
howard@marinelink.com

Editorial Contributors
Tom Mulligan - UK
Claudio Paschoa - Brazil
William Stoichevski - Scandinavia

Production
Irina Vasilets
vasilets@marinelink.com

Nicole Ventimiglia
nicole@marinelink.com

Corporate Staff
Mark O'Malley, Marketing Manager
Esther Rothenberger, Accounting

Information Technology
Vladimir Bibik

Web Contributor
Michelle Howard; mhoward@marinelink.com

Subscriptions
Kathleen Hickey k.hickey@marinelink.com

Sales
Lucia Annunziata
annunziata@marinelink.com

Terry Breese
breese@marinelink.com; +1 561 732 1185

John Cagni
cagni@marinelink.com; +1 631-472-2715

Frank Covella
covella@marinelink.com; +1 561 732 1659

Mike Kozlowski
kozlowski@marinelink.com; +1 561 733 2477

International Sales
Scandinavia & Germany
Roland Persson
Orn Marketing AB, Box 184, S-271 24
Ystad, Sweden
roland@orn.nu; +46 411-184 00

Germany, Austria & Switzerland
Tony Stein
tony.r.stein@btinternet.com
+44 1892 512777

United Kingdom
Paul Barrett
Hallmark House, 25 Downham Road, Ramsden
Health, Essex CM11 1PU UK
ieaco@aol.com; +44 7778 357722

Classified Sales +1 212 477 6700

Founder:
John J. O'Malley [1905 - 1980]
Charles P. O'Malley [1928 - 2000]
John E. O'Malley [1930 - 2019]

The Maritime Industry's Largest Social Media Presence

Maritime Reporter is a member of the Marine Media Network of websites, publications, and social media sources for news, editorial and information including the Maritime Network, the commercial marine industry's largest dedicated LinkedIn group.



63,523
Facebook Page
Likes

**MARITIME
REPORTER**
AND
ENGINEERING NEWS



148,364
LinkedIn Group
Members
(industry's largest)



42,064
Twitter
Followers

@ShipNews

All stats from 07/01/2020

Also part of the Marine Media Network



Page	Likes
Marine Electronics	33,528
Marine Technology Reporter	55,692
Maritime Global News	26,157
Maritime Jobs	46,011
Maritime Logistics Professional	30,947
Maritime Propulsion	22,477
Maritime Reporter & Engineering News	63,515
World Energy News	49,498

U.S. Flag State Control 2019 Domestic Report

The U.S. Coast Guard's 2019 Flag State Control Domestic Annual Report reflects the entire U.S. flag fleet, including barges, cargo vessels, passenger vessels, vessels operating on the Outer Continental Shelf, research and school ships, fishing vessels (though not part of the inspected fleet), and the newest members of the inspected fleet, towing vessels. With the addition of towing vessels, which started getting inspected under 46 CFR Subchapter M in July of 2018, the size of the U.S. inspected fleet grew by approximately 6,500 vessels to 19,679 in 2018. The total fleet grew again in 2019, standing at 20,064 vessels. Notably, the average age of the U.S. flag fleet grew significantly with the addition of inspected towing vessels, rising from 22 years in 2017 to 27.8 in 2018. But in 2019 this number decreased somewhat to 27.

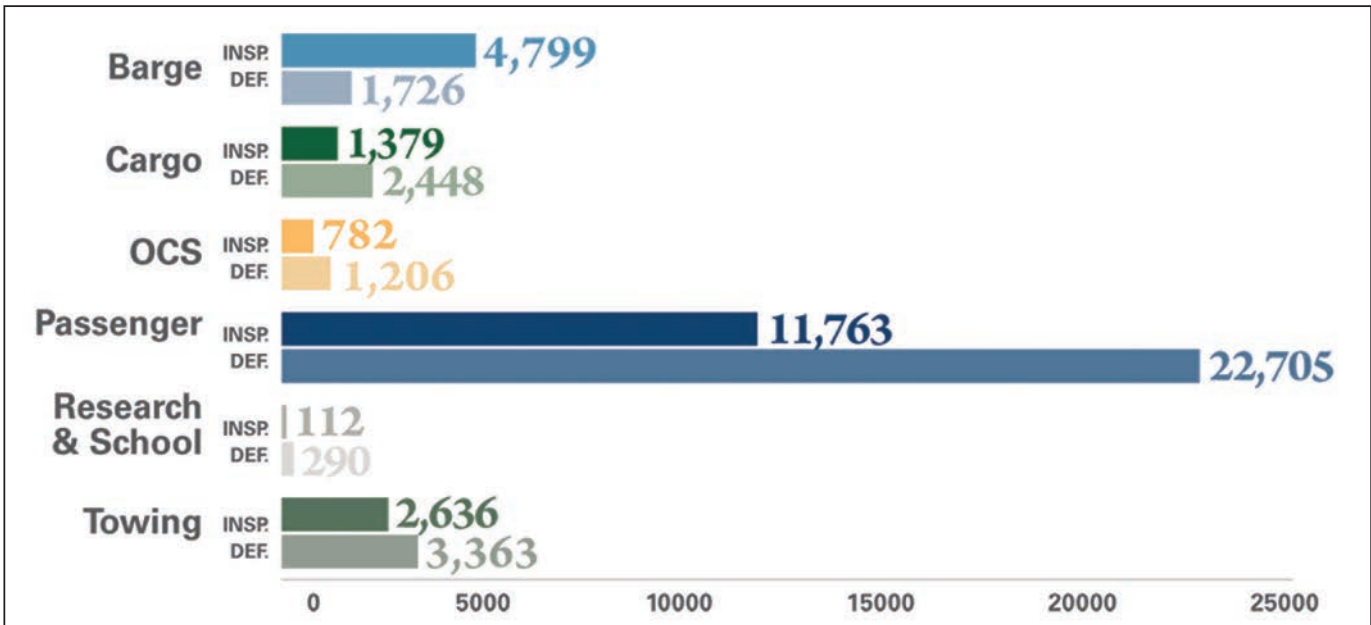
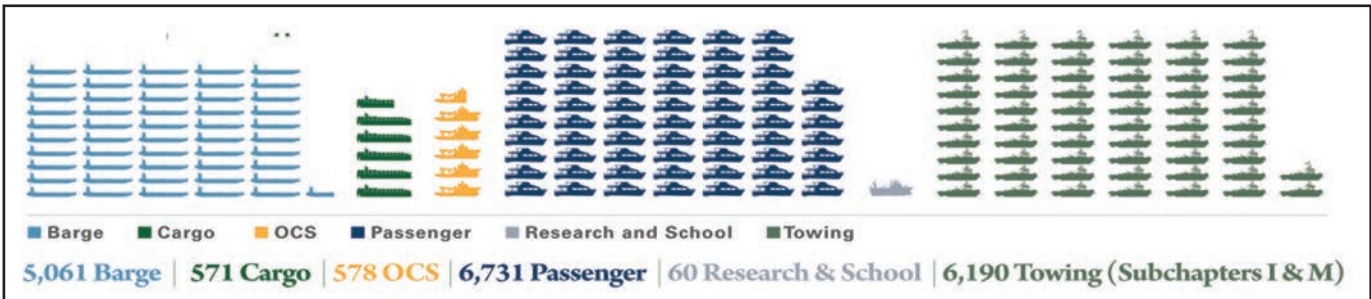



p. 28

▲
“The COVID-19 pandemic will unquestionably change the travel industry and the way we travel, at least in the near future. Travelers will be more cautious and have heightened expectations on hygiene, safety and preventive measures in place”

Capt. Havard Ramsoy
VP, Marine Operations & Safety, Genting Cruise Lines



p. 51

▲
“Our concept for an electric hydrofoil propulsion system is totally unique and will enable vessels of the future to operate with up to 90% less energy, and produce zero emissions during operation.”

Iain Percy, double Olympic gold medallist and head of Artemis Technologies

“Global offshore wind potential is technically capable of supporting more than 120,000 GW of electricity production capacity which is more than 20 times greater than current world demand.”

World Energy Report's
Outlook for Offshore Wind Power: The Frontier of Future Energy

p. 42

Capturing the Systems and Physics of



When Swiss-based Allseas Group wanted to build a simulation model to capture the systems and physics of its \$3 billion Pioneering Spirit vessel, it called on CM Labs Simulations to provide the solution. With the help of CM Labs' Vortex Studio simulation software platform, Allseas

was able to build extensible simulations that could be enhanced and modified throughout the life of the vessel.

The world's largest vessel really does have to be seen up close to be believed. The massive heavy-lift and pipelay vessel, Pioneering Spirit, is so ambitious that it was only delivered nearly 30 years after its initial design. Designed by Swiss-based Allseas Group, the 382-m (1,253 ft) long, 124-m (407 ft) wide vessel is the largest in the world. Created for the single-lift installation and removal of large oil and gas platforms and installation of record-weight pipelines, Pioneer Spirit can lift entire platform topsides of up to 48,000t and jackets up to 20,000t in a single piece. This reduces offshore work associated with installation and decommissioning by moving the work onshore where it is safer and more cost-effective.

Due to the vessel's complexity, and the continuous engineering required to build it, no simulation model has ever been developed to capture all the systems and physics of the \$3 billion megastructure. "That was basically our goal with Vortex Studio," said Allseas R&D engineer Ate te Voortwis.

Developed by Montreal-based CM Labs, Vortex Studio is a leading simulation platform for dynamics simulation and 3D visualization. Allseas' ultimate simulation objectives were threefold:

- **Train vessel operators** for teamwork-intensive activities such as ballast control, top side lift system, and steering,
- **Test new concepts** and developments in support of continuous R&D,
- **Provide project teams with a tool** for visualizing different projects (e.g., to assess clearance for operations, identify camera locations, etc.).

As mechanical engineers, the Allseas R&D engineering realized that developing their own 3D simulation toolset would involve far too much effort. Although they had extensive experience performing engineering-grade simulations in MATLAB, detailed hydraulics, they had always found it necessary to sacrifice the scale of the simulation if they wanted to include mechanical dynamics.

"Our goal was to obtain a realistically responding vessel with Vortex Studio and use lower-level tools for detailed hydraulic or structural computations as needed. All the specific components, we know a lot about, but putting them all together in a full-scale model is just not feasible."

"Vortex Studio took a lot of work out of our hands," te Voortwis adds, "namely on the dynamics simulation and 3D visualization side." One of the strengths of Vortex Studio is in accelerating design time and reduction of costly field test-

Simulation makes it possible to test operational scenarios.

Photos: CM Labs



of a \$3b Structure

ing. To prove its mettle, CM Labs first conducted a pilot project for Allseas, which consisted of building an engineering simulation for a ship-to-ship pipe handling crane, including a newly developed spreader system. This spreader incorporated a heave compensation mechanism designed to eliminate the need for manual adjustments on the part of the operator.

CM Labs simulated different cables and winches which helped them to more quickly refine their mechanical design, as well as prototyping their control systems and size components. “Without the capabilities of Vortex Studio,” te Voortwis adds, “you can’t feasibly execute something like this. The field-testing costs would be astronomical.”

Based on CAD models for the ship, a ship pedestal crane, and the rigging, as well as the basic simulation algorithm Allseas was going to use, CM Labs provided an accurate crane and ship simulation, as well as interfaces, to integrate more sophisticated algorithms for ship motion.

Vortex Studio was an excellent fit for Allseas and a complement to existing engineering tools such as MATLAB. “We conducted a serious investigation of other potential partners as well,” says te Voortwis, “and mainly chose CM Labs’ solutions because of flexibility — we knew beforehand that we would need a lot of advanced simulations.

“In the offshore business it’s common to buy a simulator that is not modifiable or extensible by the end-client. That was not what we were after, so Vortex Studio was just the best choice since it allowed for us to build extensible simulations that could be improved and modified with the life of the vessel.” Allseas’ plans for Vortex are essentially as large-scale as the Pioneering Spirit itself. “There’s a lot of time and manpower invested in the simulator right now,” says te Voortwis.

When asked to quantify the savings associated with using Vortex to simulate the Pioneering Spirit, te Voortwis is candid: “Previously this work would have taken six man-months, at 100 euros an hour. I think you can do the math there. And we would have ended up with a custom-built simulator, not with an extensible simulation platform as flexible as what we have with Vortex Studio.”

The Author

Clark

David Clark is CM Labs Senior Product Marketing Manager. A graduate of Concordia University (Montreal), he has two decades of experience in the high-tech sector.



Installation without using a single hole.



Adhesive-bonded fastening solutions:

- Require no holes
- Prevent galvanic corrosion
- Eliminate welding & gas freeing
- Reduce lagging & paint removal.



CLICK BOND®

PIONEERING > ADVANCED > SOLUTIONS

+1-775-885-8000 | WWW.CLICKBOND.COM/MR4

Shame on Port States



Port states benefit greatly from the vessels that call at their ports, loading and unloading cargoes with great efficiency and speed. The items manufactured in those states and sold overseas keep many of their citizens gainfully employed. The items imported supply stock for the stores of their nation and provide goods for their citizens. The physical ports utilized by the vessels are employment magnets, attracting a diverse array of industries.

Yet, when the COVID-19 pandemic struck, those port states took swift actions against the very vessels that keep their economies in operation. They did this, not by preventing the vessels from loading and unloading cargoes, but by banning crew changes. Thus, their economies have not suffered any immediate harm. The harm has been suffered by the thousands of seafarers doomed to sail on voyages of indeterminate

length. This harms the seafarers' physical and mental health and adversely impacts their families back home.

The United States recently issued an onerous set of requirements for repatriation of foreign seafarers on cruise ships idled in US waters. The process of gaining approval for repatriation is complex, paperwork-intensive, and expensive. Insofar as I can determine, only a handful of seafarers have been repatriated through this process. But at least the United States has done something.

Most other nations have done next to nothing.

The United Kingdom's Maritime and Coastguard Agency (MCA) recently detained five cruise ships idling in its waters for failure to complete timely inspections and to fully comply with Maritime Labor Convention requirements. Surveyors also found a number of expired and invalid Seafarers Employment Agreements, late payment of wages, and seafarers who have been on board for over 12 months. The repatriation



Photo Courtesy Robby Norman

efforts have allegedly been frustrated by shifting Indian government policy regarding its permission for return of Indian seafarers. It is no wonder that some cruise lines have found it less burdensome to sail some of their vessels to ports of the nations of its crews and return them directly to homes.

While the press has devoted a fair amount of time reporting on the plight of seafarers on idled cruise ships, few are discussing the greater problem of seafarers on cargo vessels. Thousands of these seafarers are stuck in a form of indentured servitude on their ships, unable to get replacements and return home. They continue to make ports calls, loading and unloading cargoes, loading food and other necessities, and discharging waste – but they are not allowed to go ashore. The only people that come aboard are pilots, the occasional port state inspector or surveyor, and necessary longshoremen handling cargo. Everyone maintains social distancing and many wear masks. There are no handshakes.

It could be argued that these seafarers are involuntarily being isolated from the ravages of COVID-19. They do not associate with others for weeks and sometimes months at a time. Yet, few of these seafarers have contracted COVID-19.

The toll, though, is the grind of the unending work without

break. It imposes physical and mental punishments on the seafarers. As they endure this routine, their ability to safely and thoroughly perform their important tasks decreases. This puts their ships and the environment at risk.

Singapore recognizes these risks and has approved over 40,000 crew change requests as of mid-June. Unfortunately, it is the exception. Unless other port states recognize their responsibility, as pointed out by the IMO and other international agencies, as well as by maritime labor unions, the dangers to these seafarers, their ships, and the international economy will continue to grow. Shame on the port states for allowing this avoidable situation to come into existence and then fester for months.

The Author

Bryant

Dennis Bryant is with Bryant's Maritime Consulting, and a regular contributor to *Maritime Reporter & Engineering News*.



LOCAL CONTACT GLOBAL SUPPORT

W&O is one of the world's largest suppliers of valves, actuated valves, fittings, pipe, and engineered solutions to the maritime industry. Our strategic branch network ensures you have access to experts who can offer the products and services you need, when you need them.

+1 904.354.3800 • wosupply.com



Valves | Actuated Valves | Fittings | Pipe | Engineered Solutions



PERFORMANCE

Tip #14

Drilling for Data

Collect, Analyze Data to Improve Training

A

As I wrote in last month's Training Tips for Ships, "If you do not measure it, you cannot manage it. This is especially true with training because the inputs (the training provided) are often far removed in time and apparent direct causality from the key output (performance). Therefore, it is important that we measure everywhere we can".

To address this problem, we discussed the value of student evaluations of their learning experiences and included some advice on best practices for their delivery. But typical student evaluations are just the beginning. In fact, there are many excellent sources of data which are easy to access and collect, and which can yield tremendous improvement in training experiences and outcomes. Let's look at a few of these now.

Ask Your Students (Again)!

Traditional student evaluations are delivered at the end of a course and (as suggested in last month's TTforS) about half way through the course. One advantage of that timing is that instructors have good access to their learners – since they are still in the class! However, this timing is not necessarily the best in terms of producing insightful answers. Instead, or in addition, some advocate for asking for student evaluations well after the course is finished – say 3 – 9 months after.

The value of conducting another evaluation after some time has passed is easy to understand. By waiting, the learner has had an opportunity to determine whether the learnings could be applied helpfully to their job activities. This is a critically important measure of any learning and while the student could speculate about the answer right after the course, the truth will only be known after the learner has had time to apply what was taught and reflect on its value. Therefore, when able, it is a very useful practice to conduct a short follow-up evaluation some months after the training. Questions should focus on the applicability of the learning to their work, as well as asking the respondents to identify any lasting benefits of the course, and any remaining advice for improvement.

Ask the Trainee's Supervisors:

A supervisor is often the best judge of the competency of their reports. Therefore, an often overlooked but very useful source of information as to the effectiveness of training is the learner's supervisor. As above, some time should have elapsed between the end of training and the questions posed to the supervisor; this gives the effects of training time to reveal themselves. But once the time has passed, we can ask the supervisor whether there any observable improvements in professionalism, competency, capabilities, knowledge, etc. – according to the subject of the course. This is also an excellent opportunity to ask the

Training Tips for Ships

supervisor to identify gaps they see in their reports that training might be able to close. Asking the supervisor has the additional benefit of making the supervisors first-order participants in the quest for excellence through improved training. Training of an individual is something that benefits the entire organization and all employees should not only have a voice, but should feel listened to and involved. Asking a supervisor to comment on the training of one of his or her reports is an excellent way to gather data, to demonstrate inclusivity and to generate broader interest in training optimization.

Ask the Instructor:

Finally, it has always surprised me that it is exceedingly uncommon to ask the instructor for feedback at the end of the course. That is a missed opportunity.

First, the instructor is very well positioned to know what went well and what requires improvement. He or she also often has the benefit of being able to compare the most recent offering with past offerings they have taught; students do not have that benefit. Third, instructors can usually make concrete suggestions on how to address the shortcomings observed. By asking the instructor for their feedback, including asking how the organization can better support excellence in the course, we are reinforcing the notion of shared responsibility for the learning

process. We are reminding all parties that they are accountable for excellence in learning and we are creating a document that identifies ways in which this can be achieved. These are just a few examples of data sources that are incredibly use-

ful, but often overlooked in our quest to improve training experiences and outcomes. Incorporating them as metrics in your continuous improvement process is easy and highly effective.

Stay healthy and sail safe!

The Author

Goldberg

Murray Goldberg is CEO of Marine Learning Systems which provides software and services to optimize knowledge, skills and behavior in maritime operators. Contact Murray @ Murray@MarineLS.com



OmniTHRUSTER™
Marine Maneuvering and Propulsion Systems

UNCOMPROMISED CONTROL

JT Series
Waterjet Bow/Stern Thrusters
Up to 2,200HP

HT Series

- Low Submergence Requirement
- Small Hull Penetrations
- Auxiliary Propulsion/ "Take Home" Capability
- Effective Thrust in Currents
- Proudly Made in the USA!

2201 Pinnacle Parkway • Twinsburg, OH 44087
(330) 963-6310 www.omnithruster.com



All Photo: Seven Seas Preparatory Academy

Profiles in Training:

MARCUS CHEESMAN

Founder, Seven Seas Preparatory Academy

By Greg Trauthwein

M

arcus Cheesman started his maritime training in 1987 at the early age of 13, attending Trinity House Navigation School, the UK's only Nautical school. Upon graduation he was selected for a deck cadet apprenticeship with P&O Cruises and continued to progress through the ranks with P&O Cruises, Princess Cruises, Holland America Line (including Windstar Cruises) and Disney Cruise Line, ultimately obtaining his Master Mariners license in 2002. He has piloted vessels on the busy River Humber based in his home town Hull, UK, before moving to the United States, holding positions responsible for Nautical and Marine operations and Training for Princess Cruises, Crystal Cruises and Disney Cruise Line. Throughout his career,

Marcus always had a passion for teaching and sharing his professional experience and so it seemed natural to start his own maritime training school in his new home state of Florida.

Seven Seas Preparatory Academy is a young but expanding maritime training business. Launched in 2018, it experienced 400% growth after its first year of operation, which led to expanded training programs to include yacht stewardess training, deckhand programs and cruise line entertainment training.

"We came into the maritime training business with a fresh approach and with the premise of not following the normal," said Cheesman. "From my experience working ashore in the cruise line industry and responsible for training, time was a restriction, hence I saw the need for a blended approach,"

While he started his own maritime training at a very young

Profiles in Training

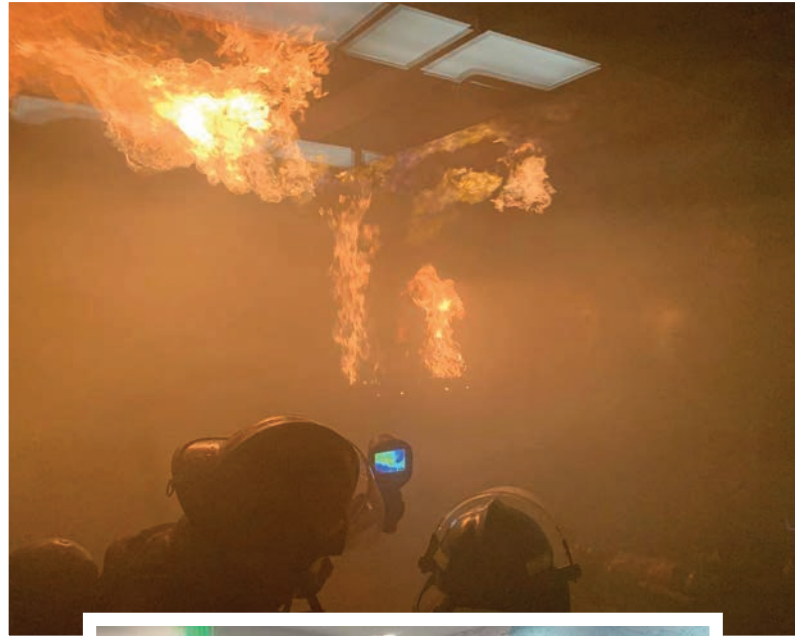



age, the trainer never stopped learning and Cheesman explains that “we also studied the needs of our students in today’s world and it quickly became obvious that our preferred training should be delivered using blended training and that we should also prepare and mentor those new to the industry.”

Today, Seven Seas Preparatory Academy is centered on an online/blended program that includes the STWC Basic Training elements, security awareness, crowd and crisis management, personnel with designated duties and deck programs.

Seven Seas Today

Today, Seven Seas Preparatory Academy primarily provides and customizes maritime training to the cruise ship and yachting industry, serving a diversity of student from first-time maritime entrants to refresher courses for students from around the world.

“In addition to STCW courses, we build customized maritime professional training programs for cruise industry, for example recently we developed a Health and Safety course for a new cruise line (Virgin Voyages) that was facilitated to all crew, when the ship was still in the yard,” said Cheesman.

Starting at such an early age in the industry has given Cheesman a unique perspective on evolving and effective training methods.

“I have attended many courses during my career with a mixture of quality and it became apparent that occasionally while attending a course was a tick in the box and to collect a certificate with no real learning value,” said Cheesman. “Today, expectations are high, and we must ensure that we create the best learning environment to aid development. We believe we a

best placed for that by delivering blended and online courses.”

While legislative mandate drives maritime education requirements and an increasing array of online tools enable distance learning, Cheesman sees practical experience as equally important. “As we need to embrace changes in technology, we believe that basic core principles must still be taught to ensure we do not become to over reliant on such technologies. This is a reason why we focus on preparing our students for life at sea.”

Give and Take

Teaching a course is one matter; gauging its effectiveness is another. “Our main focus is student feedback,” said Cheesman. “Our philosophy is ensuring that our students understand what we are teaching and not just completing a test to gain a pass mark. We have an active program in place that enables us to make changes with the goal of providing quality training with the expectations of our students.” Seven Seas Preparatory Academy’s online platform was developed by Marine Learning Systems and “has proven instrumental in reaching our needs and goals in providing online training. The system allows us to track student performance with their leading-edge reporting,” said Cheesman.

As the industry evolves, so too does Seven Seas. “We currently run a deckhand workshop for those interested in working on superyachts, where they learn valuable seamanship/navigation skills and as part of the course we shall be providing remote simulator assessments where we can operate instructor lead exercises using radar/ECDIS. We are very much embracing in this new and evolving technology.”

www.sevenseasprep.com

Profiles in Training



All Photo: Seven Seas Preparatory Academy



ENDLESS SUPPLY OF MARINE HARDWARE

REQUEST A NEW CATALOG • SALES@ANCHORMARINEHOUSTON.COM



AUTHORIZED YOKOHAMA FENDER DISTRIBUTOR

- New, Used and Rental Options Available
- New Harness Installation Or Harness Repair with Quick Turnaround
- Foam and Pneumatic Fenders Available

NEW & USED

LARGEST INVENTORY IN THE USA

- Anchors
- Chains
- Fittings
- Towing
- Hardware
- Wire Rope
- Cordage
- Blocks
- Dock
- Fenders
- Buoys
- Spill Boom

IN STOCK &
READY TO SHIP
WORLDWIDE
24/7

(800) 233-8014 • ANCHORMARINEHOUSTON.COM



Leadership development in the Merchant Marine: A growing significance for the future

By Matthew Bonvento

H

ow many times have you heard someone say, “Oh, that person is a born leader, I could never do what they do as I am not a born leader.” That train of thought has recently come under increased scrutiny and debate as the Merchant Marine enters the 21st century. As part of this focus, the IMO updated the STCW code with

the 2010 Manilla Amendments. Included in that update were training requirements for management level officers to have training in Leadership and Managerial Skills. Junior officers are trained at an operational level with the same skills: STCW 2010 outlines the requirements for Junior officers to have the following skills at an operational level and Senior officers to have been assessed for the same skills at the managerial level:

- Knowledge of shipboard personnel management and training
- A knowledge of related international maritime conventions and recommendations, and national legislation
- Ability to apply task and workload management, including:
 - 1. planning and co-ordination
 - 2. personnel assignment
 - 3. time and resource constraints
 - 4. Prioritization
- Knowledge and ability to apply effective resource management:
 - 1. allocation, assignment, and prioritization of resources
 - 2. effective communication on board and ashore
 - 3. decisions reflect consideration of team experiences

- 4. assertiveness and leadership, including motivation
- 5. obtaining and maintaining situation awareness
- Knowledge and ability to apply decision-making techniques:
 - 1. situation and risk assessment
 - 2. identify and generate options
 - 3. selecting course of action
 - 4. evaluation of outcome effectiveness

(Development, implementation, and oversight of standard operating procedures) For Management Level officers only.

At the end of the day however, the question remains, is this enough? This was a topic focused upon by both Admiral Alftulis of SUNY Maritime and Admiral Buono of USMMA during last year’s Maritime Education Summit held on the Massachusetts Maritime Academy campus. During their presentations both of the Admirals made a point of discussing how each school is focusing on training the future leaders of the maritime industry. STCW is only the mast upon which the sails of leadership can be flown. Much more is needed if the vessel is to get underway.

I thought back to my time at SUNY Maritime as a student and dug up one book which was required reading to Indoctrination officers at the time (Leadership Secrets of Atilla the Hun by Wess Roberts) and decided to re-read it after many years. After reading that I picked up James C. Hunter’s book *The World’s Most Powerful Leadership Principle, How to Become a Servant Leader*. Before I knew it, I was taking online courses in AGILE leadership and next thing I knew I had embarked upon a path of

leadership training. What I came to realize and read over and over again is that although there may be people with innate people skills that make it easier for them to lead, leadership can be taught. But furthermore, the concept of leadership training and development is an underdeveloped field, with few schools offering courses in leadership. Management yes, but leadership no.

So that begs the question. What is the difference between Leadership and Management? According to a Forbes article published in November 2016 “Leaders create a vision, managers set a goal.” This is quite a fundamental difference that does not appear to be taken into account with the STCW courses, since predominantly they are marketed as “Leadership and Managerial Skills.”

I reached out to Col. Patrick Keane, USMC (Ret.), who is the director of Leadership Training at the U.S. Merchant Marine Academy, as well as to Dr. John Ballard, (also USMC (Ret.)), the Provost and Dean at USMMA. What is apparent after speaking with them for only a few minutes is that the Marine Corps focusses in on leadership development very early on in every Marine’s career. This is accomplished in a straightforward path of allowing subordinates to take on demanding leadership roles with the supervision of a seniors to provide feedback. On the face of it, this may sound simple. However, this method requires important ideological buy in from both ends of the spectrum, validating and valuing the worth of this training. This concept is not new to the Maritime schools, which all have a regimental training system. But importing the USMC system to the Maritime Academies would allow for a deeper evaluation of each students’ leadership potential and development. There is some recommended reading by Col. Keane to accompany the training:

- *Leaders Eat Last* - Simon Sinek. Great lessons of leadership from the Marine Corps in particular and how they can be applied to business or other endeavors where the organization wants to optimize leadership.

- *Make Your Bed* - Admiral McRaven. Leadership, honorable and ethical behavior and how he’s applied what he learned in his career to everyday life.

- *Team of Teams*. GEN McChrystal talks about moving from efficiency to adaptability and how it applies to all organizations, not just the military

- *Gates of Fire*. Steven Pressfield. Fiction, but a great read about honor, ethics and leadership using the events surrounding the battle of Thermopylae

Seminars on leadership as well as assigned readings expose the students to concepts such as Servant Leadership. The style of Servant Leadership is based upon senior leaders mentoring and guiding their juniors in growth and leadership potential, all the while maintaining a positive yet realistic demeanor.

While having leadership opportunities is important, just as important is the ability of someone to follow their leader and know how to execute appropriate orders with trust. Apportion-

ing leadership training to both practical exercises and academic theory is important to develop in students the knowledge of when to lead and when to follow according to Dr. Ballard.

Training does not stop in school though. Captain Ryan Leo, an actively sailing master, discussed with me the need for senior shipboard management to instill confidence in junior officers to help them develop. Not only by providing them with the opportunity to lead on board, but by development of communication skills. One of the most effective leadership skills, according to Captain Leo, is the ability to hold direct and honest conversations. As discussed by the NTSB in the investigation report on the El Faro, the 2nd and 3rd mates should have been more forceful with the captain. But in reality, is that going to be the case on board most ships? Not always. Anyone who has sailed for that ornery, old sea captain can attest that open communication is not always easy. But directness is essential, even when unwanted. Junior officers should know when to respectfully question and voice their thoughts to a senior officer.

A commonality throughout the industry is the responsibility of any crew member to halt an operation if they spot or seriously suspect that there is an immediate danger to health. For those of us who sailed, we have all experienced the moment in our careers where we had to stop an operation to move personnel to safe positions or stop an operation before a fire broke out. These are special circumstances.

As leadership is discussed, so must the focus on managerial skills be emphasized. The STCW code lays out a great foundation for training on board managers who have the ability to conduct daily operations on board. Once again however, these skills will atrophy by the time a junior officer reaches management level, unless time is invested during their formation period. Allowing junior officers to take on tasks directing unlicensed is not unprecedented, just underutilized. Management training is a discussion for another month.

Shore side leadership should work closely with senior shipboard leadership to ascertain junior officers with long term potential within a company and provide them with ample growth opportunity as well as with encouragement. One example provided by Captain Leo was a junior engineer who reported to him a chief engineer who was preparing to bypass the Oily Water Separator and dump oil over the side. The actions of the third engineer save the ship and the company from a horrible pollution violation and what could have been a huge fine. The engineer was rewarded with a trip to the home office, a nice dinner, and other perks. This type of incentivization should not be limited to extraordinary cases. Many companies provide the Master a discretionary fund for crew awards, etc. The use of which should be encouraged to help develop potential leaders. Leadership training is the career development experienced from junior officer through senior officer up the executive ladder. The instilled confidence may help prevent future disasters.



Photo: © metamorworks/AdobeStock

Smart management is needed as wave of digitalization transforms maritime



As the shipping industry undergoes major transformation, with operations becoming increasingly automated, maritime companies need to consider more than just efficiency and safety when it comes to operations. The current global situation has resulted in a growing demand for crew communication,

for both work and social purposes, alongside the ongoing need for optimization. All of this causes higher levels of traffic on maritime networks, forcing shipping operators to place an increased focus on essential network management to protect business operations.

While on-board IT systems can be complex, they also offer large-scale opportunities for digital technologies to increase communication, reduce costs, boost productivity and ensure higher customer satisfaction. Because of this, investments in network management can have a significant impact on business operations and can also require a great deal of management and undertaking to make them pay off.

Network management

The most significant development for maritime communications has been the integration of standalone technologies into end-to-end solutions to create a manageable network. Gone are the days of shipowners and managers having to juggle boxes of the past, instead this integration offers higher network performance, simplification of operations and a reduction in the total cost of ownership.

With so many fundamental applications and processes, it has become essential for shipping companies to install a smart network management platform. This impacts everything from the seamless transition between shore-based 4G/LTE connectivity, VSAT and L-band satellite, to the operation of on-board in-

formation systems. Smart network management platforms also deliver automatic matching of demand of various applications to available networks and the management of traffic, whether that be voice, internet, email or video.

To ensure that the network can support all necessary services, operators need to utilize platforms that maintain the services and applications running on it to deliver value to all stakeholders. The network should be able to support every application required for daily operations while also offering the potential to provide new services to keep up with the ever-increasing changes in the industry.

A Reliable Platform

Having an integrated management service helps to support the whole network to carry out mission critical communications for the smooth running of operations instead of a patchwork approach which could cause potential disruption. This management service will become an integral part of maritime operations – with many aspects reliant on consistent, uninterrupted seamless connectivity. With services and applications running on the platform essential for delivering value to the ship, the business, its crew, and customers, it is critical that the network can support all elements of day-to-day operations.

Having a robust network is key for successful management and operation of the ship, where downtime and delays have no place. If a network becomes disrupted it can cause a multitude of problems for shipowners and business managers whose operations largely rely on having end-to-end network connectivity.

The system must also offer the ability to support new services in the future to adapt to the industry's changing demands. For instance, being able to support real-time analysis of integrated data from IoT sensors or provide video conferencing, voice

or email messaging similar to a traditional corporate network, these applications depend on a reliable network that is capable of handling varying levels of data at the same time.

Security First

With technology playing a pivotal role in maritime operations and with new innovations continually being developed, the reliance on digital applications and communication networks is growing. This presents a challenge for shipping companies as cyber attacks increase in sophistication and present a huge potential for devastating damage to be caused by compromise to a network. Therefore, security must be made a priority when it comes to the integrated management service, with the ability to defend itself from evolving threats.

To ensure security comes top of the list for maritime businesses, the International Maritime Organization (IMO) has made it a requirement that from January 2021, cybersecurity best practices are written into Safety Management Systems (SMS). It will be crucial for the shipping sector to think ahead about how to implement these changes ahead of the deadline.

This IMO directive is leaving operators to determine exactly where these vulnerabilities and cybersecurity gaps lie within their SMS. They must then come up with ways to fix these gaps and incorporate these new protocols which are designed to protect maritime systems from attack. This however is challenging due to a worldwide lack of maritime cybersecurity experts, meaning it could leave companies with a large bill to seek support on how best to safeguard themselves and build in these new IMO requirements.

Remote Management

While shipowners and managers are experts at turning the complexities of global business into a profit, they now require greater control and visibility of their networks and services to remain ultra-competitive. On-board systems can be vast and

complex, offering huge advantages for maintaining efficiency and boosting customer satisfaction while needing a large amount of oversight which can be challenging.

By utilizing the power of an effective, smart remote management service like Speedcast's state-of-the-art integrated management and application platform, experts on shore can retain complete control with endless visibility into every ship. This ensures shipping companies can manage every detail of operations and maintain maximum efficiency.

Enabling control of multiple applications and networks, Speedcast's SIGMA platform provides a seamless insight into business operations and crew welfare services through a flexible ecosystem that can be adapted to a customer's specific current and future needs, including leveraging the numerous benefits and efficiencies of Virtual Machines.

All of this aids shipping businesses to remain competitive with substantial cost savings, high levels of operational efficiency and a boost in productivity by adopting a solution that manages network, voice and business services along with built-in cybersecurity that contributes to the IMO requirement.

As maritime industry digitalization continues to advance due to the increasing capabilities of emerging applications and communications technology, it is critical that operators have access to solutions that can maintain the smooth running of operations along with seamless, high-quality connectivity. To this end, the sector has a bright future as network management systems continue to serve the existing and future needs of shipping companies.

The Author

Delucia

Commercial Maritime
Product Director at Speedcast



ForSea Aurora Electric Ferry

1.9 million cars annually
7.4 million passengers

Zero Fuel, Emission Free



SPBES – Battery Power for Hybrid & Electric Ships
www.spbes.com • info@spbes.com





Photo: © Tryfonov/Adobe Stock

The Path to Zero

A team led by ABS has been awarded a contract by the European Commission (EC) to explore future directions for the IMO's Energy Efficiency Design Index (EEDI) for ships.



The landmark study will look at ways to improve and accelerate the integration of low-carbon fuels and innovative technologies into the requirements of the index, which was originally created to reduce emissions from ships by promoting design improvements and the adoption of more

energy-efficient power systems.

The EC, the executive arm of the European Union, awarded the consortium of ABS, Vessel Performance Solutions (VPS) and Arcsilea with funding to assess the EEDI's technical performance and evaluate new targets before the 76th meeting of the IMO's Marine Environment Protection Committee (MEPC) in October.

The technical study will analyze the EEDI's potential to deliver better ship designs and examine its relationship to any new technologies that could improve fuel efficiency. It will also consider updated targets that could improve vessel efficiency.

To assess carbon intensity, the EEDI formula measures a ship's power consumption and generation, speed and deadweight to assign a value that represents the volume of carbon dioxide it emits when transporting one tonne of cargo for a nautical mile.

Currently in 'phase two' of its deployment, the EEDI's carbon-reducing requirements are expected to significantly strengthen when phase three enters into force in 2022. The technical study is expected to inform the EU's proposals while the IMO considers the possible introduction of EEDI's fourth phase.

The team's first task will be to review the current state of the Index's implementation, including the extent to which it has incentivized the creation and adoption of new designs and technologies, its impact on vessel speeds and installed levels of power, all in the context of the requirements for EEDI Phase 3.

This will include any limits to improving efficiency by reducing installed power while maintaining a constant fuel scenario;

the main focus will be on the types of ships that have minimum requirements for propulsion power, such as tankers, bulkers and combination carriers.

It will also examine whether the current EEDI formula adequately captures the benefits of any new design and technology applications, the influence of 'correction factors' for different ship types and any issues that may arise from the verification process.

The Role of Fuels and Technologies

The second task will be to assess how new technologies and fuels can improve the energy efficiency and carbon intensity of new ships and their power systems, including those using LNG, bio-derived and alcohol fuels.

The levels at which alternative fuels and technologies are being adopted will be examined, as will the effectiveness of the IMO's present verification guidelines. This part of the study will investigate the extent to which the requirements of EEDI phases one and two have been implemented on board ships, while concurrently assessing their effects on EEDI values and exploring ways to promote broader adoption.

It is hoped that this piece of work will increase industry understanding of why specific designs and modifications are being adopted by specific segments of the industry and why others have proven less popular. These initiatives also will provide the information for more accurate assessments of how to both incorporate new technologies and alternative fuels into the next phase of the EEDI and verify their benefit in terms of carbon reduction.

Fast-Tracking Decarbonization

The ABS-lead team has been tasked with proposing a roadmap that could link phases three and four of the EEDI, including potential ways in which any updated carbon-reduction and energy-efficiency targets could be set, taking into account ex-

isting industry analyses.

Fundamental to this process is exploring ways to speed up the adoption of low-carbon and non-conventional power solutions such as electric batteries, fuel cells and hybrid options. This will include addressing the challenges related to the carbon content of each fuel; not all have recognized carbon factors, or references in EEDI regulation. The process will attempt to identify the most effective ways to integrate promising technologies into the EEDI framework as they become available, and estimating the environmental impact of each.

Industry Consultation

The study's requirements include an extensive consultation process with industry stake-holders, including equipment manufacturers, consumers, public authorities and NGOs, with feedback informing proposals for the introduction and formulation of EEDI phase four.

Consultation tools such as questionnaires, interviews, expert panels, bilateral meetings conferences and workshops will be assessed for their ability to acquire a representative sample of stakeholder opinions.

This process is expected to include at least two workshops with administrators in order to build a consensus-based approach to the final recommendations, with the results subject to statistical analysis for validation.

A Pathway for the Future

The present EEDI formula is comprised of many energy-efficiency solutions. The study will investigate how new technologies and fuels could be adopted into the EEDI framework and contribute to the reaching the IMO's carbon-reduction goals for 2030 and 2050.

Critical to this process is verifying the impact of each technology or fuel, and whether phase three of the EEDI can incorporate any new decarbonization solutions that are gaining traction in the industry.

The study will not change the EEDI, rather it will examine opportunities to reorient the Index towards the requirements of the new age of decarbonization. Through this process we hope to discover whether the EEDI is robust enough to adopt any proposed changes while retain-ng its mandate to improve the energy efficiency of shipping and keep people safe.

The Author

Plevrakis

Georgios Plevrakis is the Director of Global Sustainability for ABS.



AS THE SEAS REOPEN

SAVE MONEY

while meeting the
0.1% or the 0.5%
CHALLENGES.

The **CR Ocean Engineering**
Marine Scrubber
guarantees **0.1%** and
0.5% sulphur fuel
equivalency even
when burning
high-sulphur fuels.

CR OE IN-LINE SCRUBBER BOTTOM INLET CR OE OFF-LINE SCRUBBER SIDE INLET CR OE U-TYPE SCRUBBER

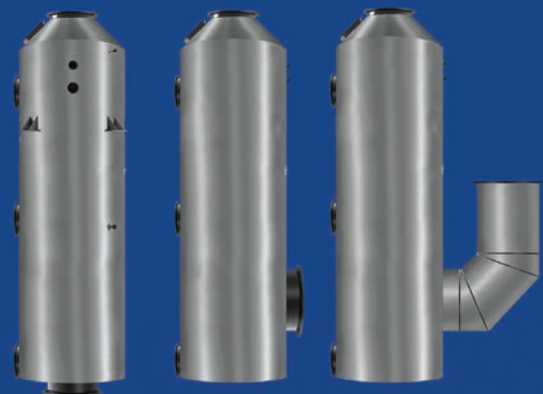

CR Ocean[®] Engineering

For more information go to:
www.croceanx.com

Or write to us: nconfuorto@croceanx.com

Freight Planning

What About Offshore Wind?

By Tom Ewing



At the end of 2019 – December 27, to be exact – the US Department of Transportation, Office of the Secretary – filed a request for information regarding the development of a National Freight Strategic Plan (NFSP), required by the multi-year federal transportation bill, passed in 2015, called the

FAST Act – “Fixing America’s Surface Transportation.”

By the close of the public comment period (Feb. 10) DOT had received 82 comments. Importantly, for the maritime industry, maritime businesses and trade groups, as well as many State DOTs, stepped up and emphasized how critical it is for a national freight plan to be multimodal, that such a plan needs to build on the strengths of each transport mode, so that, hopefully, a final plan is greater than the sum of its parts.

Interestingly, though, DOT didn’t receive any comments focused on the new and difficult freight issues presented by offshore wind (OSW). Critically, OSW ports will require specific and deliberate attention across all modes – rail, truck, marine. This will be the big stuff, too, not just a designated turn lane. These investments will be expensive. It’s not too far-fetched to think that in some states transportation infrastructure for offshore wind might need its own dedicated funding. Timing is critical, too. New York’s OSW schedule, for example, is aggressive. Port projects need funding sooner, really, right now, not later. New York has high-level estimates for some OSW port upgrades. A January 2019 study estimates it will take \$314.4 million to upgrade the Port of Albany-Rensselaer. That excludes, however, some important work, from utilities (not defined) to “public access” (roads, highways...?), to environmental mitigation. The estimate for another port, the South Brooklyn Marine Terminal: \$297 million, again excluding critical project line items.

NY’s state energy agency plans to make \$200 million available for help with port requirements. That’s a lot of money but keep in mind New York officials want the social and economic benefits from OSW investments to impact large sections of the state, at least from Staten Island to Albany. Demands from numerous ports could use up that \$200 million pretty quickly.

In its comments to USDOT, New York State officials do not mention OSW development and ports. Likewise, there’s no reference to wind energy port requirements from the Capital District Transportation Committee (Albany), a region supposedly

under consideration for wind-port development. Ditto for New Jersey officials, who are similarly planning imminent investments in OSW port facilities.

For a freight system and freight activities, OSW demands singular attention. OSW ports require large tracts of land. Manufacturing, assembly and storage logistics will require access, maybe new or upgraded access considering the size and weight of turbines and support structures. Road and highway projects are usually paid for via federal and state gas taxes. Additionally, local projects require local approvals and sometimes a local funding match. Some maritime projects are subsidized by MARAD and DOT grants, but most port upgrades are paid for either by a port’s private sector tenants or financed through the rent from those tenants. For an OSW port, all bills due may be paid largely by taxpayers and ratepayers; all costs and project financing need to be very clear, upfront. Rail, of course, largely depends on private railroads.

This is not easy work. And there are details that most American cities aren’t familiar with. Consider, for example, the extent of freight planning that occurs in some European cities.

“Even local governments have played a significant role. For example, in manufacturing and port areas, streets are designed to facilitate the passage of turbine blades and other large parts with street poles that fold flat and with traffic circles that have wide, straight shortcuts through the middle.”

That’s a description of wind-freight logistics and infrastructure in Denmark, captured in a report by Robert Collier for the University of California at Berkeley Labor Center. Is there a MARAD discretionary grant program to pay for folding utility poles at urban intersections?

These exact moves may not be required in towns in Staten Island or Humboldt Bay, CA or Cleveland, OH. But if people are thinking about a National Freight Strategic Plan, freight has to move – efficiently, safely, dependably. Otherwise, why plan? Again, the demands for offshore wind are new and they will present within America’s most populated and congested regions – from Virginia to Maine and along the Pacific coast.

It would seem, then, that in states where offshore wind is an urgent priority, there might be an effort to anticipate and coordinate the planning, financing and construction that new OSW ports will require. It would be unfortunate if a National Freight Strategic Plan were finalized without referencing the complex demands presented by building this new energy source.



OFFSHORE WIND POWER

OUTLOOK FOR OFFSHORE WIND POWER THE FRONTIER OF FUTURE ENERGY

OFFSHORE WIND MARKET INTELLIGENCE PACKAGE

The Offshore Wind Market Intelligence Package from World Energy Reports is a turn-key solution to analytics, forecasts and industry data for the offshore wind market. Each intelligence package includes:

- A comprehensive and in-depth market research report
- Interactive on-line database
- Customer support and research assistance

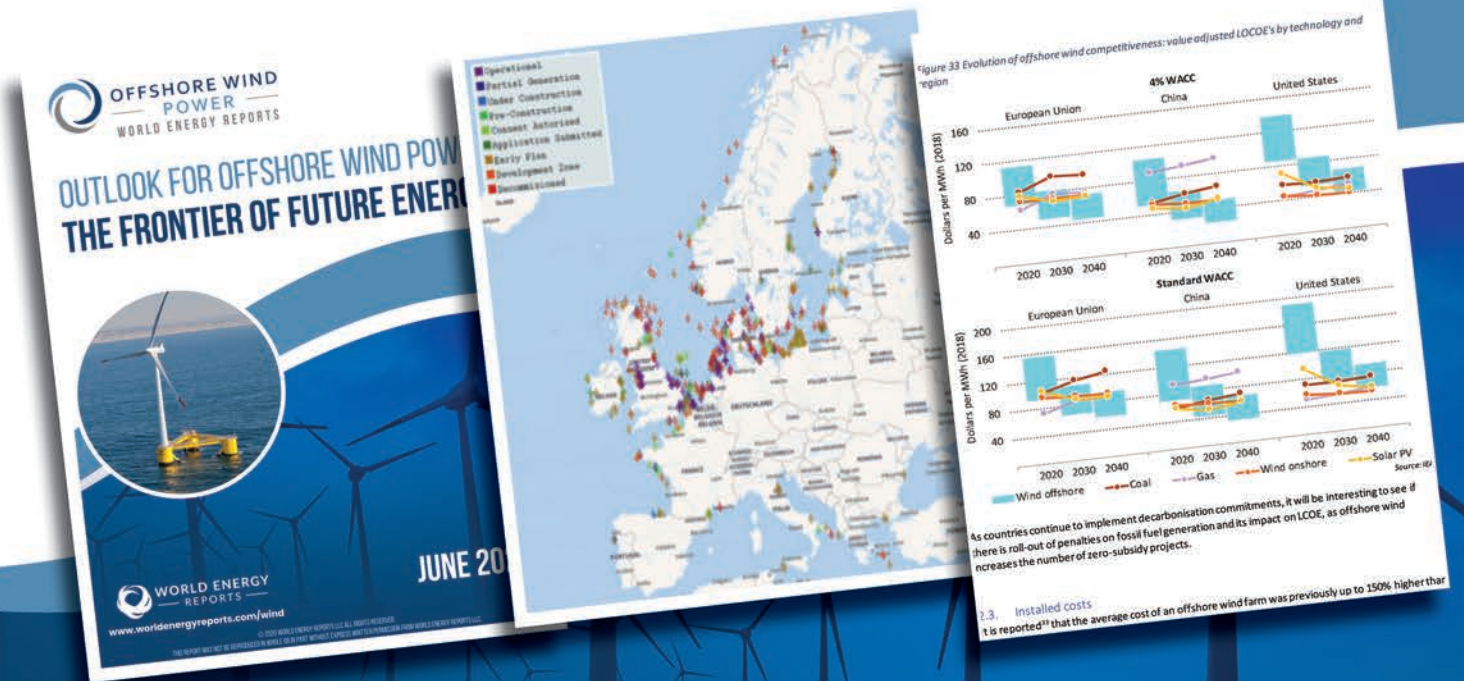

To Learn More or for Subscription Options

Call +1-212-477-6700 xt 6920
or email: info@worldenergyreports.com
www.worldenergyreports.com/wind



CRUISE DREAMS:

Plotting the Course for Safe Cruising

While COVID-19 has proven to be the biggest business disruption event in generations, for the once-booming cruise shipping industry it has meant a hard stop. Getting back to cruising will be neither fast nor easy. We reached out to **Captain Havard Ramsoy**, Vice President, Marine Operations and Safety, Genting Cruise Lines for insights on the path forward.

By Greg Trauthwein

Please give an overview of the Genting Cruise Ship fleet today, and COVID 19 and its impact on the Genting Cruise business.

Throughout the unprecedented suspension of the global cruise passenger services due the COVID-19 situation, Genting Cruise Lines' fleet, which comprises of Dream Cruises, Star Cruises and Crystal, has also been impacted with its fleet currently in hiatus.

As the health and safety of Genting Cruise Lines' guests and crew remain its top priority, various precautionary measures with stringent health screening processes had been implemented from the onset of the pandemic. As such, there have been no reported cases of COVID-19 among guests or crew while on board or transmitted via any of Genting Cruise Lines' ships to date.

During this hiatus period, we have taken the positive opportunity to implement comprehensive crew training to reinforce effective and enhanced cleaning procedures, health and hygiene protocols and efficient guest interaction, which we will adopt as the new safety norm for our fleet and we hope for the industry too. We were the first in the industry to launch and introduce our enhanced measures and we are proud also take the lead to collaborate with DNV GL towards the CIP-M certification of "Explorer Dream" under the Dream Cruises brand.

At this time, what is the official plan to start operating cruise ships with passengers?

We hope to start cruising very soon depending of various evolving factors, such as the reopening of ports and destinations, lifting of travel restrictions etc. We anticipate resuming operations in (late summer) and we can start by exploring to offer "Holiday at Sea" itineraries cruising to nowhere as the ship itself is a destination, filled with on board activities, performances and attractions. The Asian region has had a solid foundation as a cruise hub and destination with strong in market demand from short to long haul markets last year. Other regional markets also show promising opportunities with countries like China exploring to expand its "Travel Bubble" covering mainland China to Taiwan, Hong Kong and Macau, as well as South Korea.

With the COVID-19 concerns, what measures have been undertaken to help ensure that the cruise journey is as safe and healthy as possible for your customers?

The COVID-19 pandemic will unquestionably change the travel industry and the way we travel, at least in the near future. Travelers will be more cautious and have heightened expectations on hygiene, safety and preventive measures in place.



Photo: Genting Cruise Lines/Inset: DNV GL



Meeting and exceeding these expectations will become the new norm for the cruise industry. Initially, safe distancing will be a common practice which will see our guests checking-in online with designated times at the terminal to minimize congestion, on board venues operating at reduced capacity to ensure ample spacing among guests, the suspension of buffets with F&B being served instead etc. Our enhanced measures developed with the COVID-19 pandemic in mind will be the new norm that include stringent health screening processes and protocols, thorough sanitization and disinfection and enhanced hygiene practices for guest cabins, various onboard public areas and recreational activities, and increased food and beverage safety.

Hence, it's important to also continue to educate and create awareness among potential and future guests to boost confidence such as informing them of our ship designs that enable 100% external fresh air to be filtered and supplied to the cabins and on board public areas – ensuring a constant and healthy flow of fresh air with no recirculation within the ship – an important feature on our cruise ships.

You recently made news as the inaugural customer for DNV GLs CIP-M certification. Please discuss the specifics of this certification, what it will cover, its cost, as well as the perceived benefit you see that it delivers.

As part of the CIP-M certification, DNV GL assesses vessel operations, including enhanced sanitation procedures, food preparation and handling, physical distancing requirements, use of personal protective equipment (PPE) by crew members, maintenance of public health essential systems, emergency response plans, pre-boarding screening, embarkation and debarkation processes, and itinerary or port planning protocols. We benefit from a strong partner like DNV GL. Its health care expertise in infection risk management has certified 640 hospitals worldwide. This will help us to ensure our comprehensive new

measures cover everything. We hope this will help us to bring confidence to our customers that cruising will be safe the day we resume our business.

What will be the criteria to roll this certification out 'fleet wide'?

We are still discussing the next steps for the certification process.

When your customers step back on board your ships, how will the cruising experience 'look and feel' different?

As we resume operations in the near future, these will include stringent health screening processes and protocols such as mandatory temperature screening and pre-boarding health declarations for embarkation and disembarkation; thorough sanitization, disinfection and enhanced hygiene processes for guest cabins and on board public areas at a higher frequency – public areas that were previously sanitized once daily will be sanitized two to four times daily with hospital grade disinfectants.

In addition, safe distancing will be a common practice which will see our guests checking in online with designated times at the cruise terminal to minimise congestion, while guest capacity will be reduced at on board venues to provide ample space for safe distancing between guests during the initial phase of operations. Similar hygiene and safe distancing practices will also be applied to the entertainment and recreational activities.

Self-service at buffet restaurants will also be suspended. All food and beverages will be served to guests by our crew who will be wearing face masks and gloves as added precautionary measures.

Sanitizer dispensers will also be available at various public areas and crew members will be stationed at key on board venues to provide hand sanitation. We will continue to work closely with the various regional governments and also key bodies, including DNV GL, the world's leading advisor for the maritime industry, to safeguard the welfare of all guests and crew.



Five Minutes with

GEORGE WHITTIER, CEO, Fairbanks Morse

Last month Fairbanks Morse won an order by Huntington Ingalls Industries to build and deliver the four main propulsion diesel engines that will power the U.S. Navy's newest Landing Platform/Dock (LPD) ship, LPD 31, the second of 13 in the LPD Flight II class of ships. We caught up with **George Whittier, CEO**, for his insights on this contract, COVID-19 and business overall.

By Greg Trauthwein

How long have you been at the helm at Fairbanks Morse?

I returned to Fairbanks Morse in January where I previously served as CEO from 2009 to 2012. I am proud to have the opportunity to once again lead one of America's great companies. Fairbanks Morse solutions and services are mission critical for the U.S. Navy, U.S. Coast Guard, nuclear power plants, hospitals, and other commercial businesses. We have an amazing team that is laser focused on taking care of our customers, and our investors are deeply committed to the long-term success of Fairbanks Morse.

How has the COVID-19 pandemic materially impacted Fairbanks Morse' operations?

Because of our work for the U.S. military, we were considered an essential business and we have been fortunate to be able to continue operations during this time. We implemented safety protocols early on to ensure the safety of our workforce. During the lockdown, we encountered instances in which some of our suppliers were shut down and we had to creatively solve problems so that we could take care of our customers. As a result of the pandemic, we will evaluate our process for select-



The Colt-Pielstick PC2-5 STC has a power range from 5,816 - 8,725 kWb.

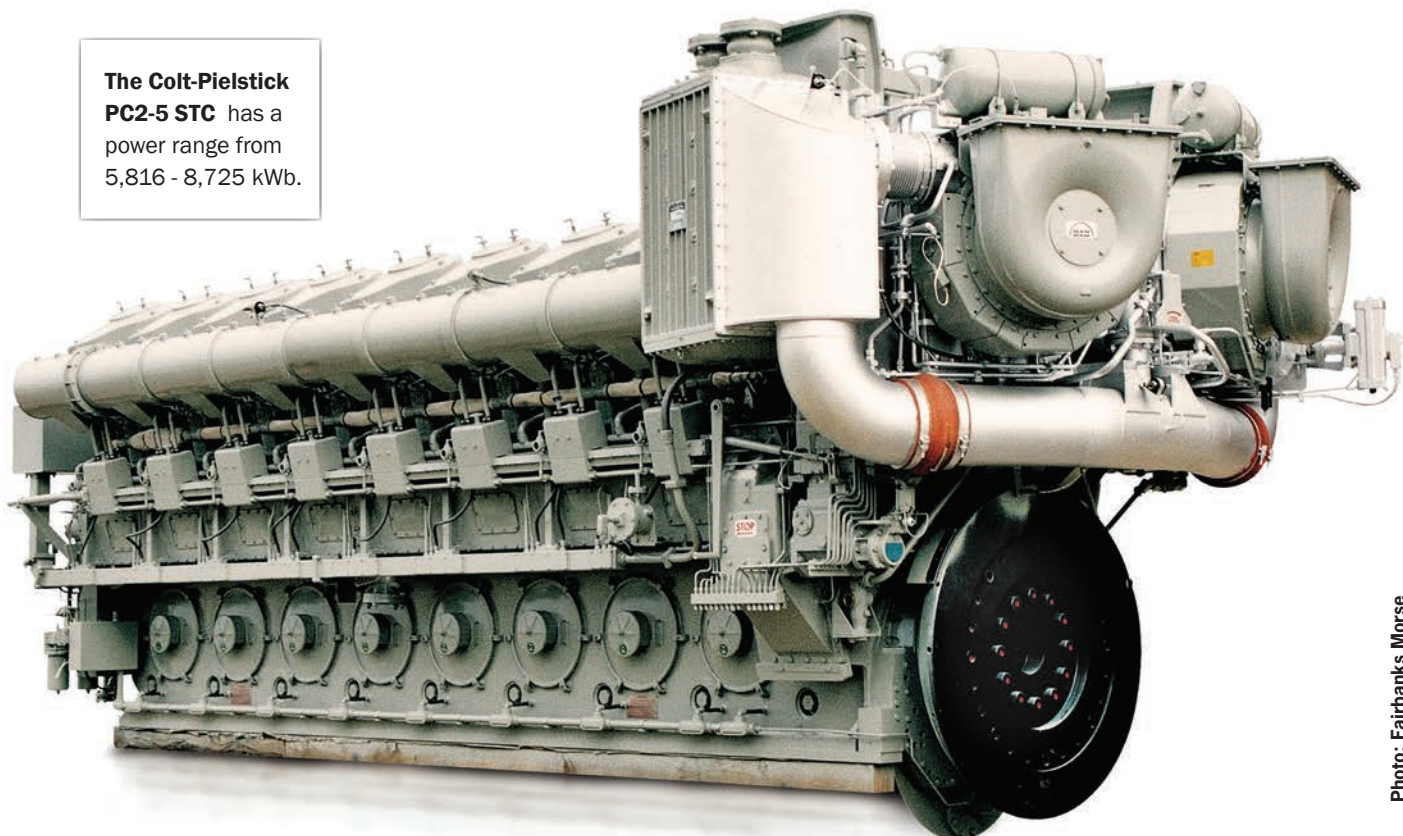

Photo: Fairbanks Morse

Inside the LPD Flight II Design

The LPD Flight II design has been modified with several additional features including an improved flight deck, a well deck, hospital facilities, and defensive features. The LPD Flight II ships also have sufficient vehicle and cargo capacities to support and sustain more than 500 combat-equipped Marines for up to 30 days. The four sequentially turbocharged 16-cylinder FM | Colt-Pielstick PC 2.5 diesel engines feature common rail fuel injection technology and will deliver more than 31 MW of propulsion power, allowing the LPD 31 to cruise at speeds of more than 22 knots.

ing suppliers and conducting inventory management so that we are best positioned to meet our customers' needs regardless of external circumstances.

Looking at this business disruption event, what is the biggest lesson learned?

We learned that we have an innovative, resilient team, that even when under pressure, never loses sight of our dedication to our customers.

Discuss the importance of the US Navy as a Fairbanks Morse customer, and your outlook for Navy business in the coming 2 to 5 years.

For more than 70 years, Fairbanks Morse has provided diesel engines for the U.S. Navy and the U.S. Coast Guard marine propulsion and ship service systems, and we expect to serve these clients for another seven decades. Fairbanks Morse engines are installed on approximately 80% of U.S. Navy ships that have a medium speed power application.

What about the recent contract?

The LPD Flight II ships will be a critical part of the Navy's expeditionary warfare mission set, which includes opposed landings, and we take great pride in making engines that may go in harm's way. Because of the common rail fuel injection

technology that goes into each engine, we are able to reduce lifetime operation and maintenance costs by increasing fuel efficiency and decreasing emissions.

To what do you attribute your long-term success in powering U.S. Navy ships?

We make every engine with care, knowing that U.S. service members rely on them to perform their duties. There are a lot of Fairbanks Morse team members that have served in the U.S. military, some are Navy veterans, and there is a huge sense of pride in being able to continue to serve by providing safe and reliable power systems. Fairbanks Morse has decades of experience working with the U.S. Navy, so we can anticipate their needs and build our services around anticipating those needs.

PROPULSION

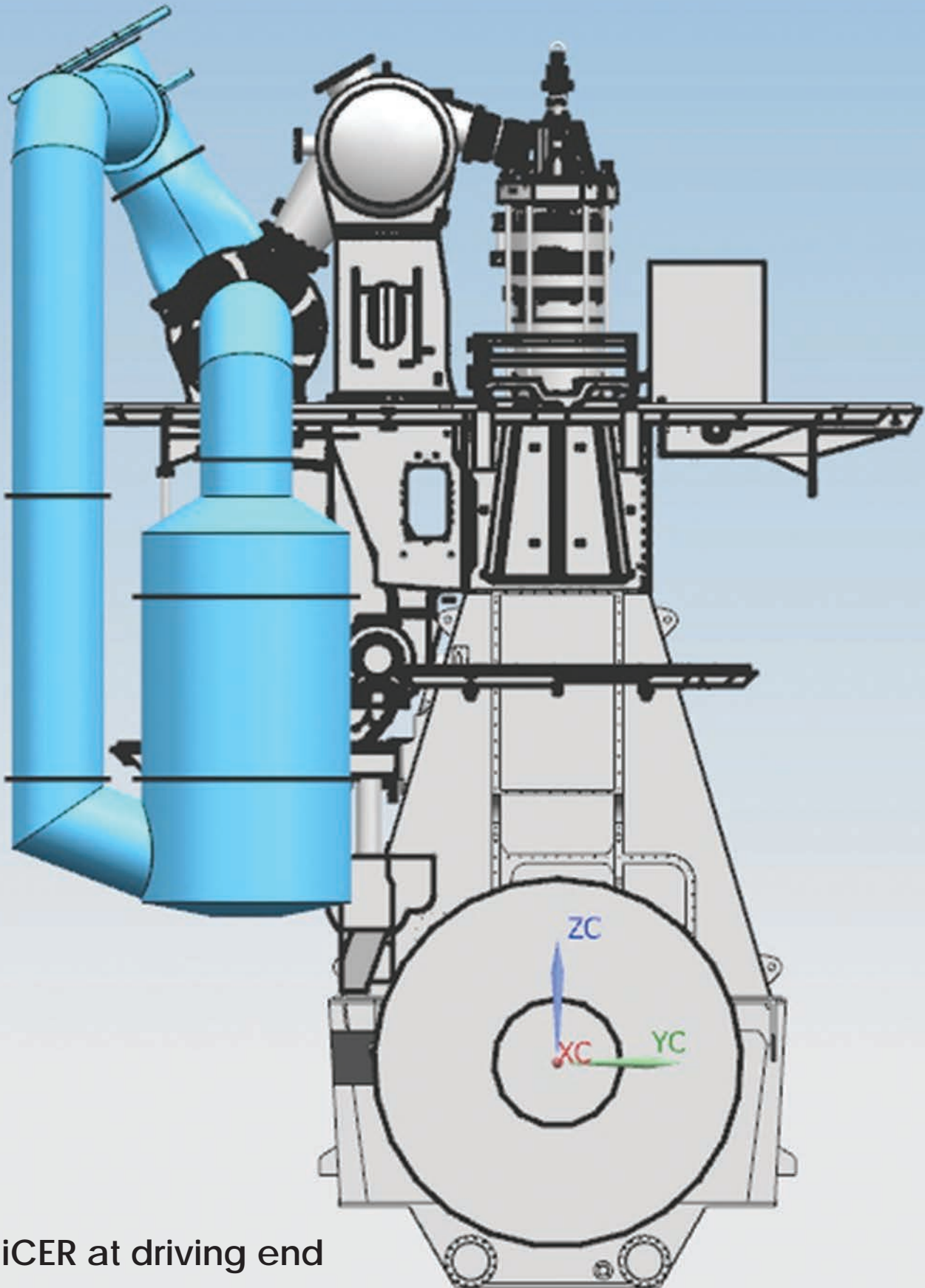

iCER at driving end

SHIP POWER:

WinGD Debuts X-DF2.0 Technology

By Greg Trauthwein

Developments in marine power today are centered on ever tightening legislative mandate which increasingly aim to dramatically reduce and eventually eliminate greenhouse gas emissions to the environment. While the holy grail of being truly ‘emission free’ is still not feasible, there is much concurrent work in industry and academia to develop and source the fuels, the machinery technology, the logistical infrastructure and the business case for solutions that will meet the 2050 50% emission reduction mandates from the International Maritime Organization (IMO). It’s a step process, and last month WinGD unveiled a new technology designed to slash methane emissions and cut fuel consumption in its X-DF dual-fuel engines via Intelligent Control by Exhaust Recycling (iCER), the first development to be introduced as part of X-DF2.0, WinGD’s second-generation dual-fuel engine platform.

While much of the recent progress and success in dramatically reducing emissions from commercial vessels has come in the small boat category – vessels with short, defined routes – progress on the big, two-stroke engines that power the world’s largest ships will take longer, as the technical and logistical hurdles are higher.

“I think it’s important to see the internal combustion engine as not a part of the problem but a part of the solution,” said Dominik Schneider, Vice President, Research and Development, WinGD. “We see hybrids and electrification will be a big part of the steps toward 2050.” WinGD is active in a number of simultaneous studies on the optimization of large two-stroke

engines, and Schneider said that there needs to be a holistic view of not just the engine, but the entire power package, the entire engine room. He said that with a combination of existing and emerging technologies, from PTOs to batteries to smart management, “there is still possibility for 10 to 20% improvement in total propulsion system efficiency.”

X-DF2.0

WinGD’s X-DF2.0 technologies are designed to enable improved engine performance with both LNG and future carbon-neutral fuels, while the iCER system is designed to deliver enhanced combustion control through the use of inert gas. The result, according to WinGD, is a reduction in methane slip emissions of up to 50% when using LNG and a significant reduction of fuel consumption, of 3% in gas mode and 5% in diesel mode. On the matter of methane slip reduction, Schneider, explains: “What we can do is try to capture and burn the methane. With the iCER recirculation system we give the methane a second chance to burn; (with the iCER technology) we can nicely control the combustion in the cylinder”

“Our next-generation X-DF2.0 technologies will prepare our engines for even better performance, both with LNG and with the future fuels to come,” said Volkmar Galke, WinGD Global Director of Sales.

The development builds on the WinGD X-DF platform, which at press time had logged 550,000 hours of operation premised on 60 engines operating in the field, and 320 engines sold all together.

PROPULSION

"I think it's important to see the internal combustion engine as not a part of the problem but a part of the solution."

**– Dominik Schneider, Vice President,
Research and Development**



"Our next-generation X-DF2.0 technologies will prepare our engines for even better performance, both with LNG and with the future fuels to come."

**– Volkmar Galke, WinGD Global
Director of Sales**

Advancing the performance of dual-fuel engines comes neither quickly nor cheap, and this latest step has taken nearly five years from inception to delivery. "By adjusting the recirculation rate of inert gas and controlling parameters like fuel admission and ignition timing, we can increase compression ratios for greater efficiency," said Galke. "The result is optimized combustion through closed-loop control regardless of ambient conditions and load."

Like all future X-DF2.0 technologies, iCER will be available for all new X-DF engines. It is currently completing trials at one of WinGD's dedicated test engine facilities – the final step in a two-year testing program. The company is also finalizing plans for a pilot installation.

The pilot installation is interesting as according to Galke the vessel is a small ship, under 2,000 TEU, designed without the iCER technology. The process to fit the equipment into a tight engine room space is proving valuable, as the retrofit market is a target for the iCER tech.

As well as using fossil LNG, X-DF engines can also burn carbon-neutral synthetic or bio-derived LNG when it becomes available. According to Schneider, while much of the 'fuel of the future' chatter centers on fuels derived from renewable sources, fuels from biomass should not be forgotten, particularly with the supply and demand challenges in creating an delivering renewable created marine fuels in the volume needed to fuel the world fleet of ships.

X-DF2.0: Lessons Learned

As with any new technology development, there are glitches, hurdles low and high to traverse in the delivery to market, and the X-DF2.0 is no exception.

"The industry was skeptical about the low pressure on the two stroke engines – citing knocking and combustion problems," said Volkmar Galke, WinGD Global Director of Sales. "Luckily (all of the issues encountered to date) have been technical problems that are able to be solved, and not concept problems. **So the biggest learning here is that the combustion process is stable and we have it completely under control.**"

According to Dominik Schneider, VP, R&D, WinGD, the X-DF platform is unique due to the very high percentage – from 95% to 98% – that the engines have run fueled by LNG. "The high utilization of the gas system on these engines is really unique. They really just switch to diesel fuel when they have to, according to IGF code, which is for maneuvering, and once a week to ensure that the fluid injection system is not blocked." He said that one of the biggest lessons learned with the engines operating predominately on LNG is centered on the cylinder lubrication oil deposit build ups, particularly when shipowners are using high BN numbers. Schneider said it was learned in CIMAC working groups that **"cylinder lubrication oil developed for HFO and MDO applications are not necessarily the best oil for LNG applications.** This is being addressed with the oil industry."

MODULAR EXHAUST

Super Lightweight

Cost Effective

info@e4powerllc.com

Maritime Today

E-News Service

In business, time is of the essence.



Stay up to date with the latest
NEWS & INFORMATION...

...from the industry's leading source; providing you with daily updates on the subjects that pertain to your business.

www.marinelink.com

AUTONOMOUS SHIPS



Photo: © videotrinkets/AdobeStock

Understanding Marine Autonomy:

Today's Market and Future Concerns

By Jake Gerlach, PE

AUTONOMOUS SHIPS

trate every market segment, companies ignoring it risk finding themselves stuck behind their competition. Smart observers are asking what the autonomy trend means for their jobs and businesses, watching this developing market, and looking for ways to engage and prepare for the future.

MARKET REVIEW

Marine autonomy covers a spectrum ranging from relatively low-cost commodity vehicles to large-scale defense projects. Commodity autonomous vehicle products aren't particularly new. Mature UUVs and remote-control survey boat products are available today from a number of providers. Commodity autonomy is characterized by vertically integrated manufacturers and well-defined product lines. On the other end, military projects are leading the research and development of full-scale ships that are truly autonomous. The key driver for these projects is the government's willingness to spend significantly to mature new technology and deploy it. Recent programs like the Navy's MUSV and LUSV offer large build quantities, encouraging significant industry investment to develop advanced solutions for the government.

Between the ends of this spectrum is a vast and varied market. Ships and boats in the middle of the spectrum are most often unique to the demands of a specific task, location, route, and operator. As vessels in this market begin employing autonomy technology, this diversity will grow. Companies delivering commodity autonomy products have the benefit of vertical integration, designing every detail of their products, and often accomplishing production in-house. Defense projects are developed by large prime contractors with deep experience designing and integrating complex sensors and computer systems. In the middle, ships are often designed in stages, where concept, contract, and detail design might be undertaken by separate companies. Although the market in the middle will leverage technology developed at the ends, it will require different solutions that can be readily and easily adapted by a wide variety of designers, builders, operators, and environments.

The middle market is also the most limited by the absence of a clear regulatory framework. Various demonstration projects have taken place in the past several years in several different commercial applications. Despite the technological successes of these projects, in most cases they represent a proof-of-concept without a clear path towards regulatory acceptance to enable broader use.

A parallel spectrum of remote supervision and autonomous support systems is also developing. This design space is bracketed by truly autonomous vessels at one end. On the other, autonomy technologies are deployed with a goal to improve the performance of crewed vessels. In between are many variations including remote control and human supervision of automated ships. A promising development is the adaptation of sensing technologies and collision avoidance algorithms into products designed to serve strictly as operator aids that supplement normal crewing practices.

Press coverage of early commercial marine autonomy projects is remarkably broad given the small number of marine industry professionals engaged in bringing these projects to market. The much larger assembly of industry stakeholders are left wondering what marine autonomy means for them. Regulatory, cost, and technical challenges stand in the way of fielding today's autonomy technologies for most existing fleets and vessel missions. Autonomy is coming whether you're prepared or not. While it may not pen-



Autonomous Guard Vessel concept design

NEW CHALLENGES, NEW SKILLS

Fully autonomous ships are not yet a viable solution for most applications. While specific contributing technologies have been demonstrated, we have yet to see these pieces integrated into a compelling commercial demonstration for sophisticated autonomy without close human supervision. The regulatory environment is developing slowly but still leaves great uncertainty. Despite these challenges, there is no doubt that autonomous ships are coming. Various projects have demonstrated capable remote-control systems and the US Navy has conducted fully autonomous operations with the Sea Hunter. Will autonomy be a major disruptor with a broadly applicable business case? Yes. It seems likely that there are great opportunities for early adopters. Organizations willing to invest in maturing the technology may secure a competitive advantage by realizing the benefits of autonomy before more conservative players.

The primary challenge implicit in autonomous ships is losing the great adaptability of a human crew. Even remote-control systems that retain humans in the loop constrain human flexibility because no remote-control interface can replicate the versatility of a human walking around the ship. Today's typi-

cal control systems require operators with deep experience and broad understanding of the ship's systems and environments to filter through data and nuisance alarms to determine what information is truly actionable. Our standards for integration will have to evolve so that remote control and autonomous fault response become normal design considerations for subsystems.

Control systems on autonomous ships must integrate subsystems more tightly, virtualizing lower level components into simple models that higher-level autonomy algorithms can effectively use to make decisions that properly balance equipment status against operational needs.

Reliability will remain an important requirement for marine equipment, with new importance on the ability to accurately communicate problems and required corrective actions to the control system. Commissioning and testing autonomous navigation systems requires comprehensive checkout of individual sensor performance, correlation between sensors, communication between subsystems, and tests of backup and emergency modes. While the technical horsepower to work through major design and commissioning issues may remain with autonomous system vendors, builders and owners will need to care-



Photo: C-Job

fully consider their project schedules and required testing conditions to build an efficient and executable plan.

New and improved skills will be needed. Prime contractors will take design responsibility for specifying an overall network concept, approving subsystem designs, and defining the physical and logical interfaces between systems. Shipyards and boatbuilders will require increased sophistication in capabilities for procurement, integration engineering, installation, commissioning, and testing.

Ship design has always required cross-disciplinary teams. Both autonomous ships and ships with more limited automation demand growth in the sophistication and expertise in naval architecture firms.

The deployment of this new technology will favor designers with a demonstrated history of creativity and ability to develop new and novel solutions. A deliberate and well-designed ship-wide network will be required at the concept design stage, and controls engineers must define robust interfaces between subsystems. In some cases, simpler system designs will be a better solution than adding multiple layers of redundancy and instrumentation. In other cases, designers will need to offer systems that can

gracefully degrade, losing capability incrementally and allowing remote or autonomous realignment. There will be much greater use of actuators and sensors throughout the vessel to provide situational awareness and fault tolerance.

Ship owners and operators will ultimately be the drivers of this transformation. Where the use of autonomy technology offers compelling advantages, operator demand will push suppliers and regulators to offer solutions. At the same time, using these technologies will require new skills from operators. Masters will need to define virtual “standing orders” through the autonomy system’s interface. Post processing of the vast amount of data generated from computer-generated mission logs will offer optimization opportunities to operators that learn to interpret it. Shore-based maintenance will grow with an increased focus on electronics specialists with expertise to maintain network, control, and sensor systems. A comprehensive continuous testing program will be essential to ensure the systems operate as intended.

CONSIDERATIONS FOR ADDING AUTONOMY TECHNOLOGY

The acquisition or design of a new automation technology or autonomous vessels requires special consideration of cybersecurity, equipment obsolescence and standardization.

Cybersecurity – getting this right requires expertise, but don’t expect an expensive consultant to easily patch up a bad design. If cybersecurity isn’t an important consideration starting from the autonomous vessel’s concept design, it can’t be effectively cobbled on the end. Owners and designers need to engage with cybersecurity requirements from the beginning.

Equipment Obsolescence – upgrading control equipment is disruptive and costly. Planning for mid-life overhauls should be included in the initial design with consideration of the ever changing landscape of technology and vendors. The ideal autonomy system makes use of discreet modules with open interfaces. The lifecycle impact of proprietary control systems and interfaces must be weighed against the comprehensive capabilities offered by the largest controls providers.

Standards – customers must demand standardization as autonomy technology matures. You wouldn’t accept unique flanges requiring custom engineering for all the components in a piping system. Designers, builders and owners should expect the same for autonomous technology.

A number of open formats are suitable, but it will take time and strong market demand push penetration of new standards into the market.

DON’T WAIT FOR DISRUPTION

If recent technological disruptions in other industries offer any guide, early anticipation is the key to success. While the technology and regulations might not be fully in place today, the shipbuilding design and procurement timelines require immediate consideration of a future with widespread use of MASS. How will your operations be affected?

AUTONOMOUS SHIPS

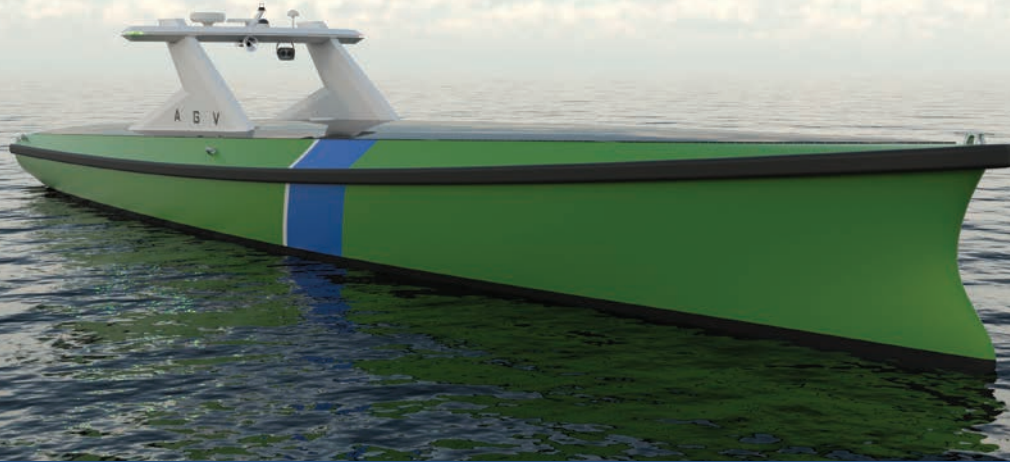

New Autonomous Guard Vessel Concept Design for Offshore Wind

Photo: C-Job

The concept design of an Autonomous Guard Vessel (AGV) – touted to ‘revolutionize the offshore industry’ – was created by a consortium of maritime companies. Designed to be smaller and lighter, with lower operating costs premised on the subtraction of crew, the AGV came to life in a project group facilitated by LISA, a community for maritime professionals. The project group resulted in a consortium, which includes C-Job Naval Architects, SeaZip Offshore Service, Sea Machines and recently joined by MARIN and eL-Tec elektrotechniek BV.

The Autonomous Guard Vessel is specifically designed for surveillance of offshore structures throughout their life cycle, ranging from wind farms to substation platforms and cable routes. With any area that needs to be secured, the AGV can continuously monitor nearby marine traffic visually as well as via radar and AIS data.

“Guard vessels perform an essential job, however, it is not the most exciting one for crew,” said Pelle de Jong, Founding Partner LISA. “Combined with the fact that conventional guard vessels are mostly outdated and thus aren’t necessarily the most comfortable let alone sustainable, it can be difficult to find well-trained crew willing to do the job. The group set out to improve upon the overall

process of securing an offshore area while incorporating sustainable solutions and reducing overall cost.”

Some key characteristics of the proposed vessel include:

- Unmanned, Self-righting
- Battery-powered: 12 hours of continuous operations would require 174 kWh battery capacity. Alternative options are being explored, too.
- Solar panels across the top to ensure continuation of navigation and communications in case the batteries run out of power
- Dimensions 11.7 x 2.07 x 1.5m; Draft: 0.55 m
- Max. interception speed: 15 knots
- Search and Rescue (SAR) modus Life raft on-board which can be deployed in emergencies
- Full AGV able to be stored and transported in a 40 ft. container.
- In addition to protecting offshore structures, the Autonomous Guard Vessel could also be deployed for surveillance of cable/pipe laying operations, mitigation of piracy activities, and illegal fishing; Sustainable aquaculture; fish, crustaceans, mollusks, aquatic plants, algae, and other organisms, border protection (Coastal surveillance), firefighting operations, line handling in port, subsea route survey, etc.



**THE MARITIME
INDUSTRY'S GLOBAL
INFORMATION
GATEWAY**



**THE INDUSTRY'S #1
NEWS SOURCE**
Including features on
managing risks in the
maritime industry



Maritime Network
Group



@ShipNews



Maritime
Reporter

www.MarineLink.com

A photograph of an offshore wind farm under construction. In the foreground, a large blue vessel named 'SEA JACK' is positioned on the water, equipped with a tall blue crane and other heavy machinery. Several white wind turbine towers are visible in the background, extending into the sea. The sky is overcast and grey.

OFFSHORE WIND

Photo: Ørsted

Offshore Wind: The Tr

Offshore wind represents just a small piece of the world's energy supply, but that's changing faster than ever before as new and existing players look to tap the huge resource potential being unlocked by shrinking costs and technological advances. In the coming decades, the rapidly maturing offshore wind market is expected to become a trillion-dollar business as the pace of installed capacity growth accelerates, according to World Energy Reports' (WER) *Outlook for Offshore Wind Power: The Frontier of Future Energy*, published last month.

By Eric Haun

GROWING, WITH HUGE POTENTIAL

Globally, the total installed energy capacity for both onshore and offshore wind farms at the end of 2019 totaled 651 gigawatts (GW), or about 10% of global electricity generating capacity, according to the WER report. While just 25.5 GW, or less than 0.5%, of that installed capacity is currently located at sea, the rate of new installations offshore has been growing at a much faster rate since 2010: 26% compound annual growth rate (CAGR) compared to 14% for onshore. Even amid the current coronavirus pandemic, WER expects this trend to continue, with 16 GW of additional offshore capacity to be added in 2020 and 2021, driven primarily by ongoing activity in the well-established Northern European sector as well as the newer, fast-growing Chinese market. China, already the leader onshore, emerged as a major offshore wind player in 2018 and has continued to expand its substantial project pipeline.

When comparing onshore wind vs. offshore in terms of untapped potential, it's clear that offshore is simply unmatched.



Photo: Jan De Nul



Photo: SAL Heavy Lift

Trillion Dollar Business

The WER report estimates global offshore wind potential to be technically capable of supporting more than 120,000 GW of electricity production capacity (equating to approximately 420,000 TWh), which is more than 20 times greater than current world demand.

By 2040, WER forecasts offshore wind capacity will increase to somewhere in the range of 340 GW-560 GW, led by Europe and China, with newer entrants the U.S., Japan, South Korean and India among top markets. The report identifies some 500 GW of projects and development zones currently in the planning and development stages, mainly coming from Europe, Asia and the U.S. Details for each project are laid out in the report as well as in a corresponding online database (<http://www.worldenergyreports.com/wind-db>).

LOWER COSTS

Offshore wind farms are not new; they have been around for decades. So why is offshore wind taking off faster now than

ever before? WER's report points to a combination of factors helping to grow offshore wind's role in the world energy mix. The simplest but most important reason for growth is that offshore wind has made great strides over recent years to become increasingly cost competitive compared to other energy sources, including fossil fuels. In the years ahead this momentum will only build as costs continue to fall.

The growing volume and size of offshore wind projects, along with improving supply chain competencies larger, more efficient turbines (the current largest is 14 megawatts (MW)), and the utilization of offshore transmission substation hubs have all helped to reduce offshore wind's levelized cost of energy (LCOE). According to WER, LCOE has declined from a global average \$170/MWh in 2010 to strike prices of \$60/MWh to \$110/MWh in 2016 to 2018 European and U.S. auctions. Recent prices have been seen as low as \$47/MWh in recent European auctions. WER says declining LCOE is allowing offshore wind to compete with fossil fuel projects in

OFFSHORE WIND



Photo: Rovco

European and Chinese markets. It's still a different story in the U.S., but WER sees cost parity by the end of next decade. Today, installation capital expenditure (capex) cost for bottom-fixed turbine projects averages just over \$3,000 per kilowatt (KW) with transmission. WER projects this will fall to \$2,500/KW by 2030 and \$1,900/KW by 2040.

FLOATING FUTURE

Another significant factor leading to a major jump in pro-

jected installed capacity over the coming years is the advancement and commercial demonstration of floating offshore wind turbines, which open up new areas to exploit: specifically, in deeper waters where the construction of wind farms was not previously feasible. Currently almost all offshore wind power generation comes from bottom-fixed turbines, which are restricted to water depths of about 60 meters or less. However, as concepts continue to evolve and become proven, floating turbines will enable wind farm construction in deeper waters



Photo: Siemens

World's most powerful offshore wind turbine

Wind turbine maker Siemens Gamesa has unveiled a new SG 14-222 DD offshore Direct Drive wind turbine with 14 MW capacity.

The capacity can reach up to 15 MW using the company's Power Boost function, a 222-meter diameter rotor, 108-meter long blades and a 39,000-square-meter swept area.

The 14 MW capacity allows one SG 14-222 DD machine able to provide enough energy to power approximately 18,000 average European households every year.

Approximately 30 SG 14-222 DD offshore wind turbines could furthermore cover the annual electricity consumption of Bilbao, Spain, Siemens Gamesa said.

The turbines have already been earmarked for the proposed 2,640-MW Dominion Energy Coastal Virginia Offshore Wind (CVOW) project in the U.S.

The prototype will be ready in 2021 with the turbines expected to be commercially available in 2024.

OFFSHORE WIND

that hold some 80% of the world's wind capacity potential. Representing another boost for overall capacity potential, these areas are typically further from shore where the wind generally blows stronger, resulting in higher turbine capacity factors.

Today's most proven floating wind turbines are Equinor's Hywind, employed on the 88MW Tampen project, and Principle Power's WindFloat, being used on the 50MW Kincardine project, but WER's report looks at more than 50 floating wind concepts in various stages that are being studied across the globe. Just as is occurring for traditional fixed-base turbine projects, the increasing size of floating projects and the industrialization of the hull construction process is helping certain concepts reduce project LCOE. For example, as Equinor matures the technology, it aims to bring the LCOE of Hywind projects to €40 -60/MWh by 2030.

A pipeline of more than 50 GW of floating capacity requiring \$93 billion to \$148 billion of capex investment has been identified by WER. As is the case in the bottom-fixed segment, the U.K. presently has the largest floating pipeline at more than 25 GW, followed by Norway (more than 5 GW) and Japan, the U.S., South Korea, Ireland, France and Taiwan, each with multi-GW pipelines. WER's report highlights the development of a much large pipeline after the middle of this decade, with potential zones discussed in the U.S., Japan, Norway, U.K. and France.

BIG POTENTIAL MEANS BIG OPPORTUNITIES

Forecasted near- and long-term increased activity bodes very

well for the global supply chain. WER expects offshore wind projects will require between \$1 trillion and \$1.5 trillion of capex over the next two decades. Much is still on the table for the gamut of suppliers and marine services firms, as 80% of offshore wind projects detailed in the report and database are still in early stages of planning and development.

With a pipeline of activity so large, there's plenty of work to be had by existing players and new entrants alike. We've already seen a number of traditional offshore oil and gas players—from operators such as Shell, Total, Equinor and Repsol, all the way down the supply chain—transfer their skillset into the offshore wind market over the years. For these firms and others, including traditional offshore oil and gas players such as yards for jacket and HVDC substation fabrication, as well as for construction and assembly of floating foundations, opportunities abound as projects get larger, deeper and further from shore.

Offshore wind farms need servicing, creating even more work for a wide range of support providers—from boatbuilders to turbine technicians. In Europe, for example, onshore operation support bases are having associated positive impacts (long-term direct jobs, and bolstered local supply chains) in port regions that had been historically active but have struggled more recently due depressed oil and gas and shipping markets. Using the current UK \$94,000/MW/year operational expenditure (opex) cost, the current pipeline of projects could require up to \$46.6 billion of annual opex spend within the next decade, says WER.



Photo: Bourbon

Principle Power's WindFloat

Bourbon Subsea Services has recently towed the third—and final—Windfloat Atlantic project's floating wind turbine to the offshore location located 20 kilometers from Viana do Castelo on the Portuguese coast.

The turbines are installed aboard Principle Power-patented WindFloat floating support structure. Similar to offshore oil and gas facilities, Windfloat uses seawater ballast to submerge approximately 2/3 of the structure below the mean water line. As for its mooring system, it is a catenary configuration connected to drag embedment anchors.

Principle Power is a leading company in DeepFarm consortium, which is developing a pioneering mooring system for deepwater floating offshore wind platforms.

The DeepFarm project's aim is to enhance currently available open-source software tools for floating turbine design in order to optimize innovative mooring system components for robust operation and lower floating wind cost.

Tech Files

Innovative products, technologies and concepts

Big Bearings Boost Offshore Pipe Laying



As the offshore industry struggles with depressed oil pricing for nearly six years running, more than ever it is taking a sharp eye to the bottom line, revitalizing equipment when practical instead of buying new. Recently, SKF helped Norwegian offshore equipment manufacturer National Oilwell Varco (NOV) achieve just that by supplying it with a unique set of bearings ... all told three different types of bearings totaling more than 28 tons.

SKF supplied a huge order to Norwegian offshore equipment manufacturer National Oilwell Varco (NOV), amounting to more than 28 tonnes of bearings in three different types.

Equipment used in the offshore industry is expensive and expected to last for decades. If market conditions dictate that equipment must start to run more efficiently, and a common approach is to replace major bearings, allowing the equipment to handle more rigorous conditions such as higher loads or faster speeds.

Among other things, NOV builds handling and pipe-laying equipment for offshore vessels. In a recent upgrade, it needed to ensure that the bearings on two cable drums could withstand

the tough conditions of unspooling pipe into the sea from a pipe-laying vessel.

Conditions on pipe-layers are hugely challenging, as the bearings are under constant loading, both radially (from the load itself) and axially (from the continuous motion of the ship on the sea).

“It requires very complex engineering because of the uncertainty from the micro motions of the ship,” said Daniel Ortiga, Senior Business Developer at SKF. The challenge for the bearings had nothing to do with speed, as the drums turn at around one-third of a revolution per minute. Instead, the difficulty was to design bearings that could take enormous loads while moving at such slow rotation speeds.

As well as achieving this, SKF managed to design bearings in standard ISO dimensions, meaning they can be found within its catalogue. Strange as it may seem, these are standard bearings, the largest ISO-sized bearings that SKF has ever supplied.

The order comprised six separate bearings in three different types: spherical roller bearings (SRBs); spherical roller thrust bearings (SRTBs); and self-aligning CARB bearings. The bearings were used on two different cable drums, one large and one small.

The large drum used four bearings, in an alternating SRTB/SRB/SRTB/SRB arrangement, which were mounted onto the main shaft. This in itself is a unique arrangement. The smaller



drum used two bearings, an SRB, and a CARB. The CARB helped to correct axial and radial misalignment. Overall, the total weight of the bearings was 28 tons, with the largest single bearing weighing eight tons.

While this is a unique order, it is not the first time that SKF has supplied bearings of such huge dimensions. Two years ago it supplied a three-ton sealed SRB to a copper mine in Peru. Here, the sealed bearing was fitted to a horizontal shaft on a roller press, which operates in very dusty conditions.

SKF recently celebrated the centenary of the spherical roller bearing, which it introduced in 1919. Back then, the product was a completely new way to overcome angular misalignment in rotating machinery, and available in a limited range of sizes. Despite the many changes to spherical roller bearings over the last 100 years, these latest SRBs, such as SKF's very first one, will be produced in Gothenburg, before being delivered to NOV in Poland.

BUILT FOR PURPOSE

We build pumps for handling water, oil, chemicals and slurries for both the public and private sectors. We offer a full industrial product line with horizontal, vertical, single, and multistage pumps. Our pumps are engineered to handle high flows, high pressures, extreme temperatures, aggressive materials and/or entrained solids.



 **CARVER PUMP™**
Built for purpose

LEARN MORE AT
Email: sales@carverpump.com
www.carverpump.com

Tech Files

Innovative products, technologies and concepts

Ventilation: Keeping Cool on the Ship, in the Yard

Heat mitigation in the machinery space is critical to equipment longevity; heat mitigation in work spaces is critical to productivity. Curtiss Wright is well-suited to handle both courtesy of its Coppus ventilation product line. Michael Chrzan, a sales engineer at the company for 30 years, is on the front line to ensure that customers get the products they need, and those systems perform as advertised.

Looking at your line-up, which product(s) are used in the marine industry for engine room ventilation?

Products used in engine room ventilation include the Air Max 12, TE 2,200 CFM – exhaust and supply air; the Cadet, TE or EP 867 CFM – exhaust and supply air; the Vano 175CV and 250CV, TE or EF 1,500 and 3,000 CFM – equipment cooling, exhaust and supply air; the Double Duty Heat Killer 24K07 to 30K30, TE or EP 7,100 to 17,000 CFM – equipment and personal cooling; and the TA16-5000 and 5500, TE or EP 5,000 to 5,500 CFM – exhaust and supply air.

What are the key technical attributes to your ventilation systems?

Besides the general information such as rugged construction and powder coating to prevent corrosion, we offer units specifically designed for maritime use.

- TM Units: Ventair TM-4, 5, 6, 8 and 9 – exhaust and supply air.
- Air Max 12, TE 2,200 CFM – exhaust and supply air.
- Cadet, TE or EP 867 CFM – exhaust and supply air.
- Vano 175CV and 250CV, TE or EF 1,500 and 3,000 CFM – equipment cooling, exhaust and supply air.
- Double Duty Heat Killer 24K07 to 30K30, TE or EP 7,100 to 17,000 CFM – equipment and personal cooling.
- TA16-5000 and 5500, TE or EP 5,000 to 5,500 CFM – exhaust and supply air.

How would you classify the problems your clients are trying to solve?

Most who approach us are familiar with our product offerings. We have been visible in the industry for many years and clients have either used our products previously or have seen them in use and seek us out. As our products are geared more to the construction and maintenance aspects of vessels, engine room applications would most commonly be related to area ventilation, personnel cooling and equipment cooling. Units that would normally be used to address these requirements are our Cadet and TA-16 air movers for area ventilation in supply or exhaust. Vano units are used for cooling of specific equipment. Double Duty Heat Killers provides high volumes of air for personnel cooling. Our units are desirable due to their portability, high air flow and rugged design and durability.

The marine market is challenged today due to COVID-19. How has this materially impacted your business?

The recent pandemic has had a negative impact on our business from a sales aspect. In talking with our representatives who have multiple product that they market, their sales across the product lines that they represent have also been negatively impacted. Our company has remained fully open throughout the pandemic. Other companies were forced to close, and many of those that remained opened have delayed projects or scheduled maintenance that would utilize

our ventilation products. Since the vast majority of our ventilator components are sourced from United States companies, there was minimal disruption in our supply chain.

We are part of Curtiss-Wrights Fleet Solutions division and are considered an essential business. Our ventilators are applied for use mainly for construction and maintenance. They are used in shipyards for both supply and exhaust during construction, for cargo tank ventilation and for equipment cooling in the engine room.

What other application areas are targets for your solution?

Coppus offers cargo hold ventilators that can be operated on water, air or steam.

These units are popular among the shipping industry and can be provided in both supply and exhaust applications. An optional duct adapter is also available so that duct can be extended into the cargo hold for extraction of heavier than air gasses. Our Ventair Shipyard Kits are popular in the shipbuilding industry. They are centrifugal units and offer high static pressure which allows for the attachment of long lengths of duct. The Ventair units can provide either fresh air or hazardous fume extraction to confined space work areas. The units are available in five sizes from 1 to 30 horsepower. Various sizes of both shipyard and standard units are quite popular with the submarine industry.

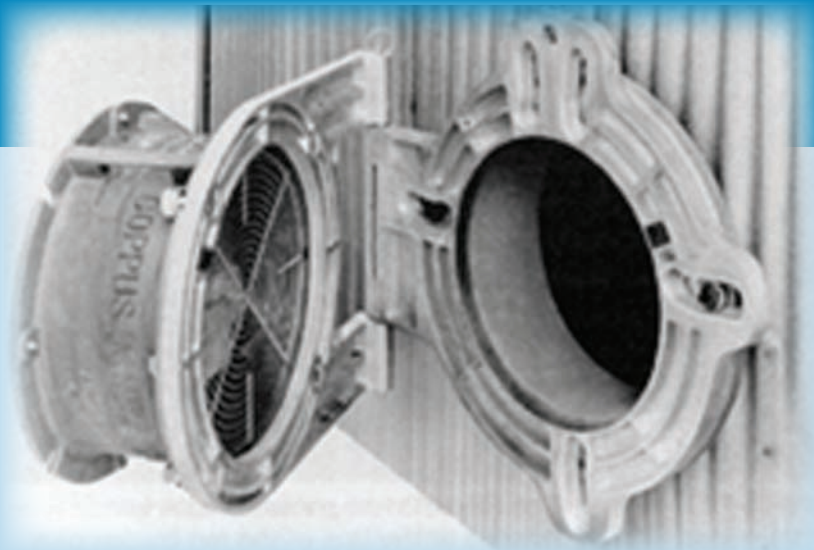

“Our ventilators are used in shipyards for both supply and exhaust during construction, for cargo tank ventilation and for equipment cooling in the engine room.”

Michael Chrzan, Curtiss-Wright Fleet Solutions, Coppus Portable Ventilation

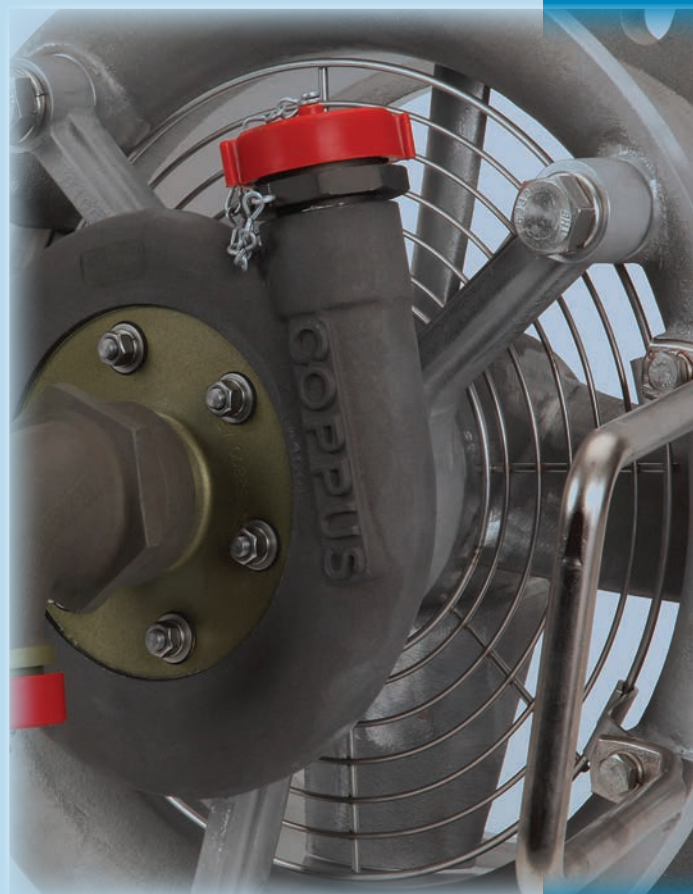

Tech Files

Innovative products, technologies and concepts

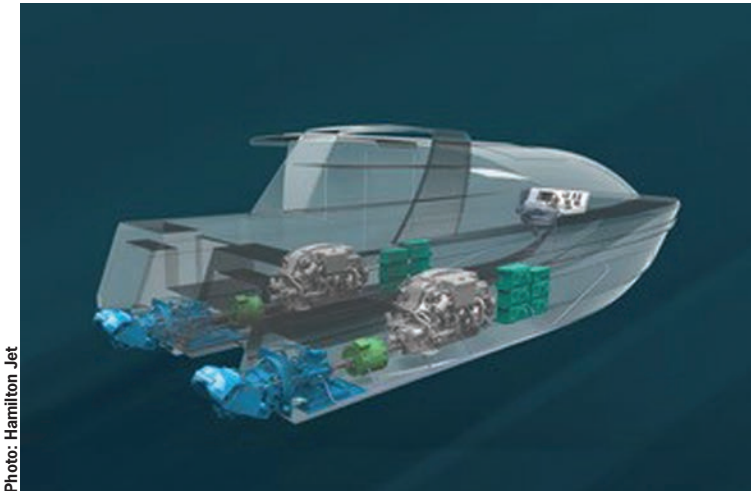

Photo: HamiltonJet

Electro-Hybrid Drive Debuts

HamiltonJet unveiled its new Electro-Hybrid Drive (EHX) system, which it says offers all the advantages of electric drive with the full capabilities of diesel. The system is designed to deliver lower fossil fuel consumption combined with the speed, maneuverability, efficiency and safety of waterjets. With EHX, HamiltonJet delivers the electric motors, power electronics and control system seamlessly integrated with the waterjets, engines, gearboxes or clutches.

The control system manages the hybrid energy flow between engines, batteries and motors, while charging and discharging the batteries as required. There are four different modes of operation: diesel only, electric only, charging or electric boost. EHX can also be configured for an electric-only vessel with the option of a fully integrated HamiltonJet solution. HamiltonJet recently acquired a 15-m aluminum hydrofoil-assisted catamaran test boat that it is refitting with the new EHX waterjets. Previously a recreational vessel used for cruising the waters of New Zealand's Marlborough Sounds, the vessel is bound for a relaunch following the refit as the showcase for HamiltonJet's newest technology.

Voith's eVSP

With the new electric Voith Schneider Propeller (eVSP), Voith is pushing ahead with the continuous electrification of its drive technologies. The eVSP features a permanent-magnet synchronous motor integrated in the propeller. The complete omission of gears reduces noise and frees space on the ship. In addition, the eVSP offers ship operators a degree of flexibility in the choice of power generation (energy source) as well as low maintenance requirements. Furthermore, the eVSP features favorably weight characteristics and can be mounted without any shaft train restrictions.

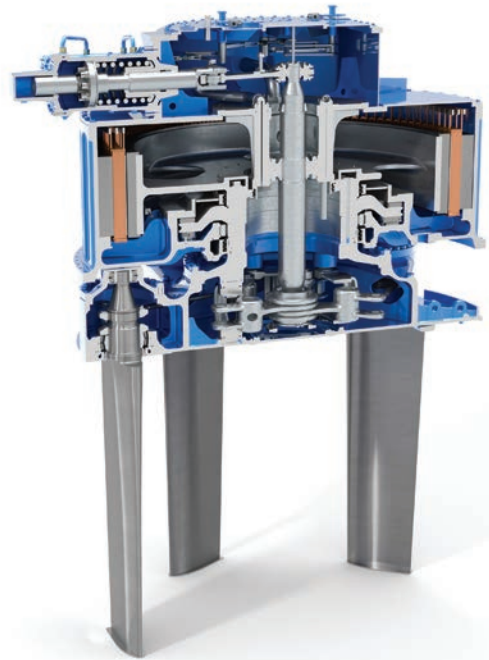

Photo: Voith



Magnetic fall protection

McNetiq launched a new line of magnetic anchors for fall protection when working at height. The operator is connected to this anchor with a measured working line so that the worker can never get past the unsecured edge.



AlphaFeverCamera

JRC/Alphatron Marine introduced a Body Heat Camera in response to COVID-19. The Body Temperature Measurement Camera which is able to measure object's temperature at a high accuracy in real time, with accuracy up to $\pm 0.5^\circ\text{C}$.



Yacht Nav Systems

Sperry Marine and Telemar Yachting have collaborated on bridge systems for superyachts, including the 54-m MLR, which has completed a successful first year of voyages with no downtime to its bridge systems.



SafeSea EPIRB1 Pro

Ocean Signal developed what it calls the world's most compact Category 1 (auto-deploy) Emergency Position Indicating Rescue Beacon – the SafeSea EPIRB1 Pro, which is 30 smaller compared to other EPIRBs, the company said.



Photo: ABB

Hybrid for Live Fish Ship

A 77m diesel-electric live fish carrier will feature ABB hybrid power and propulsion solution with integral energy storage. The 77m-long diesel-electric vessel is being built at the Aas Mek. Verksted AS shipyard in Vestnes, Norway, for Nova Sea Service AS, one of Norway's largest producers of Atlantic farmed salmon. Due delivery in September 2021, Færøysund is Aas Mek. Verksted AS second newbuild for Nova Sea Service AS. ABB's scope of supply consists of an electric, digital and connected propulsion package comprised of two ACS880 drives and two permanent magnet motors, the energy storage system including a battery pack, low voltage switchboards, and a power energy management system (PEMS).

Based on a proprietary design, the live fish carrier includes a 3000 cu. m. load compartment which can be separated into two wells, and a pressure loading and unloading system. Its water treatment, oxygenation and circulation systems use ultraviolet light to eliminate pathogens and filters to control fish lice.

Zero Emission Ferry Funding

A Belfast Maritime Consortium led by Artemis Technologies won a \$42m UK Government innovation grant to develop zero emissions ferries in the city. Counting investment from partners, the total project investment will reach close to \$75m over the next four years. A spin-off from the America's Cup sailing team, Artemis Racing, Artemis Technologies is led by double Olympic gold medallist Iain Percy OBE. Salient design details include a design capable of carrying up to 350 passengers, propelled by "an electric hydrofoil propulsion system is totally unique and will enable vessels of the future to operate with up to 90% less energy, and produce zero emissions during operation," said Percy.



The 350PAX ferry concept and the electric hydrofoil propulsion system.

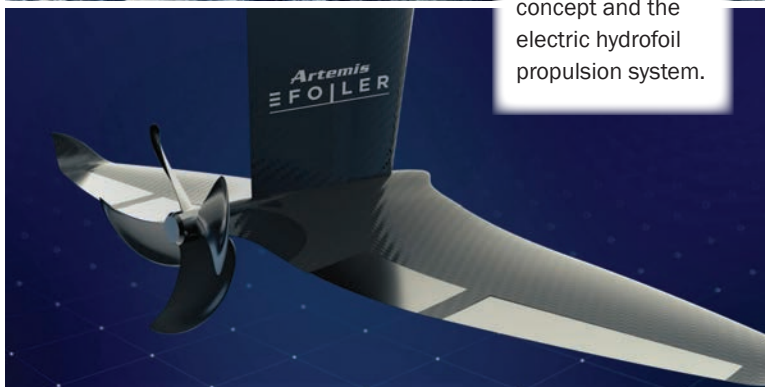

Photo: Artemis



HYDROCAM Bolt Tensioners
HYDROCAM hydraulically operated bolt tensioners axially stretches bolts and studs, using a pre-determined residual load to create a high integrity fixing, which can be mounted and dismantled quickly and safely without damage.



HexPly M79 Prepregs
Hexcel received DNV GL Type Approval Certification for its HexPly M79 prepreg materials, which are well suited to marine composite applications since they can be cured at temperatures as low as 70°C for eight hours or 80°C for four hours.



Flow Batteries
Flow-Mar is a new project to assess the feasibility of using flow batteries in vessels to enable zero-emission marine propulsion and auxiliary power. The consortium includes: Houlder, Swanbarton, Lloyd's Register and Marine South East.

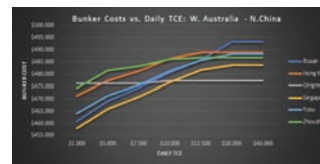

BunkerPlanner
BunkerPlanner calculates bunker port calls that can be induced on a voyage in relation to the costs of bunkers, port calls, barges, and deviations, while also taking into account a speed up of the vessel to meet a fixed ETA at next port call.

In the Yard

New Ship & Boat designs, contracts & deliveries



Eastern Shipbuilding

ESG Launches Sandy Ground

Eastern Shipbuilding Group, Inc. (ESG) launched the second of three new Staten Island “Ollis Class” Ferries for the City of New York Department of Transportation (NYCDOT) Staten Island Ferry Division. The Sandy Ground was launched at Eastern’s Allanton facility in Panama City, Fla.

The three Ollis Class double-ended 4500 passenger ferries, are from a design provided by Elliot Bay Design Group, with each ferry featuring four ABS Electro-Motive Diesel (EMD) 12-710 at 900 rpm EPA Tier 4 marine propulsion engines with two engines powering one ABS Reintjes DUP 3000 P combining gear and one ABS 36 RV6 ECS/285-2 Voith Schneider Propeller at each end of the vessel. Power generation is provided by three ABS, EPA Tier 3 marine continuous duty diesel generator sets, Caterpillar C18 driving 480 V, 60 Hz, 3-phase generators rated at 425 kW at 0.8 P.F. at 1,800 rpm.

The new Staten Island Ollis Class Ferries series are named after fallen soldier of the US Army 10th Mountain Division at Fort Drum, ‘Climb to Glory’, Army Staff Sgt. Michael H. Ollis, a Staten Island native killed in Afghanistan on August 28, 2013 serving during Operation Enduring Freedom. The first of the series, Hull 219, is named in his honor.

Zvezda Begins Building World’s Most Powerful Nuclear Icebreaker

Russia’s Zvezda Shipbuilding Complex has cut first steel for the leader project’s flagship nuclear icebreaker Russia, said to be the world’s most powerful.

The Zvezda shipyard, owned by a consortium led by oil giant Rosneft, is working with Atomflot, a subsidiary of Russian nuclear group Rosatom, to build the icebreaker, which will help boost year-round commercial vessel traffic on the Northern Sea Route connecting Europe and Asia along Russia’s northern coast.

Scheduled to be commissioned in 2027, the icebreaker will be equipped with two RITM-400 type nuclear reactors, four turbines and four electric propulsion motors. The ship’s total power capacity of 120 megawatts (MW) will be at least double that of other icebreakers currently in service or under construction.

The newbuild will be able to sail through ice more than 4 meters thick at a speed of 2 knots, and will be capable of speeds up to 12 knots in ice that’s 2 meters thick. At 210



Photo: Zvezda Shipbuilding Complex

Berlin’s new “Editorial Ship” Powered by Schottel

Having been in the marine publishing business for nearly three decades, it is increasingly rare to find a purpose-built vessel that is truly unique, but across my desk today comes news of the delivery of “The Pioneer One”, Germany’s first “editorial ship.” Delivered to Berlin-based media company Media Pioneer, the vessel is envisioned as a “floating editorial hub”, providing a workplace for around 30 journalists.

“The Pioneer One” was built by the Lux-Werft shipyard in Niederkassel, it is propelled by Schottel propulsion units, specifically Schottel Pump Jet type SPJ 22 with 90 kW input power, driven by an electric motor. The resiliently mounted bow thruster minimizes structure-borne noise in the

hull while significantly reducing the noise level on board. The result is a low-emission propulsion unit with an electric thruster that works so quietly that those on board the ship can fully focus on their work. The technical specifications are designed for daily use on the Spree River and all zone 4 inland waterways. The ship measures 40 x 7 meters and sports 200 square meters of space, which includes TV broadcasting facilities and a podcast studio. “The Pioneer One” travels on the Spree River in the centre of Berlin’s government district. Although headquarters to the editorial team, readers will also be allowed to visit the ship. Live broadcasts and events are planned for up to 100 participants.

– G. Trauthwein

meters long and 47 meters wide with a draft of 13 meters, the icebreaker will be able to clear a path about 50 meters wide, enough space for vessels with carrying capacity over 50,000 metric tons, as well as Arc7 liquefied natural gas (LNG) carriers with hulls 50 meters wide.

Zvezda, which was chosen to build the icebreaker at the direction of President Vladimir Putin, officially signed the order contract with Atomflot in April.

The shipyard, which is currently operational but still under construction itself, was also put into service at Putin's instruction, to build various vessel classes including those that had not previously been produced domestically such as Arc7 LNG carriers used to transport gas from the Yamal LNG plant in the Russian Arctic. The yard presently employs a workforce of about 3,500, which will grow to more than 7,000 by the time the shipyard is completed in 2024.

Zvezda's order book currently amounts to 39 vessels, with options for another 20, including 28 vessels for Rosneft. Its first newbuild, a 114,000 dwt dual-fuel tanker for Rosneft, was launched in May.



Photo: BMT

LNG-fueled RoPax Ferry

Willem Barentsz was built by Strategic Marine Shipyard in Vietnam while final outfitting and commissioning were completed by Rederij Doeksen.

With an operating area within the Wadden Sea, a UNESCO World Heritage Site, the main focus for Rederij Doeksen was on reducing the environmental impact of the vessel operation. BMT provided the technical solution to reduce NOx, CO2, and noise while increasing the efficiency of the design.

The propulsion system selected is based on the new MTU pure gas engines; IMO Tier III and EU stage V compliant engines built to deliver 1,500 kW and drive the Veth VZ contra-rotative unit to achieve a service speed of 14 knots. The Doeksen ferry includes maximum capacity of 600 passengers, 66 cars, 120-meter truck lane, and six crew members. The vessel operates at a service speed of 14 knots.



Photo: Schrottel

Perfecting on-time performance

Recent reports show that on-time performance in the containership sector continues to deteriorate, causing tension between the carriers and retailers. In general, non-ocean carriers – trucks and trains – are achieving reliability rates well above 90% whereas containerships rarely beat a 70% on-time threshold. For retailers, the threat of having empty shelves is beginning to swing the balance from cheaper ocean transport to a need for reliable just-in-time deliveries supplied by other transport modes.

Delays and congestion at loading and discharge ports tend to cause the most significant delays but at-sea issues also create disruption. Poor weather, machinery breakdowns, navigational re-routing and crew problems are all potential culprits. Carriers find it difficult to mitigate port-related delays, but problems caused at sea can be handled more effectively. Maintaining visibility over vessel schedules and individual voyages allows operators to take informed and rapid decisions when things go wrong and this goes a long way to improving reliability.

In today's world of available global communications, with readily accessible – and affordable – software, containership carriers now have the opportunity to install intelligent solutions that allow them to more effectively monitor and control their fleet.

The first step is to create an efficient and reliable schedule. Using a modern software solution, operators are able to take all relevant company data and marry this with distance tables and other external information to automatically generate a long-term schedule and workable ETAs. Using a range of simulated scenarios, this schedule can be tested for robustness, reliability and realism before it is released for use. As all carriers are in constant dialogue with a range of outstations, partners, ports and custom-

ers the software must communicate, in real-time, up-to-date schedules and any changes to all those who might be impacted.

Once implemented, and as each voyage gets underway, the software must accept real-time updates from the ships themselves. AIS feeds, noon reports, arrival and departure notices and other information should be accepted directly into the software allowing the vessel operator to quickly identify if the vessel is running to schedule or deviating from its planned voyage.

If a delay is identified, clever software will allow the operator to lift the individual voyage from the live operational environment and run a series of alternative scenarios to identify the optimum measures to get the ship back on schedule with minimum delay. Voyage and routing instructions can then be passed direct to the master. Getting an early indication that a delay is imminent allows the carrier to inform all those likely to be impacted, and this will go some way to help mitigate the problem.

Aside from the likelihood of upsetting the cargo owner, delays also have the potential to add significant cost to a deviated voyage, particularly if more fuel is likely to be used. However, the same software used to simulate the voyage deviation options should also estimate the impact on bunker consumption associated with any route and/or speed changes. The operator can then trade these costs against the impact of disrupting the planned schedule. The software will advise if schedule changes will cause on-board bunker stocks to fall below a pre-set minimum and highlight where best to take on new supplies. Taking a further step, intelligent software might also link to a related facility to streamline the bunker purchase process and, later, reconcile the bunker invoice

against contracts and volumes. Bunker costs and consumption are extremely high on most operators' agenda and the need to monitor and manage different grades of fuel is a more complex process now that the International Maritime Organization (IMO) sulphur cap is fully in force. Having software automate a large part of this activity removes a headache for the vessel operator.

With reliability issues continuing to creep into the containership sector, it is important that carriers do all they can to mitigate the possibility of supply chain delays. Some issues are beyond the control of the carriers themselves, but other factors can be handled and mitigated efficiently. Modern software solutions can play an important role in assisting vessel operators in optimising their schedules and minimise disruption when things go wrong. These powerful IT and software facilities were once only available to those carriers with deep pockets and wide-ranging resources. Today, however, software is much more accessible and should be utilised to help keep supply chains moving and customers happy.

The Author

Fischer

Lars Fischer is Managing Director of Softship Data Processing Ltd, Singapore,



a wholly owned subsidiary of Softship AG, the leading provider of software solutions to the international liner shipping sector. Softship is part of the WiseTech Global group.

Give your online advertising real IMPACT, an exclusive tracking tool for online advertisers.

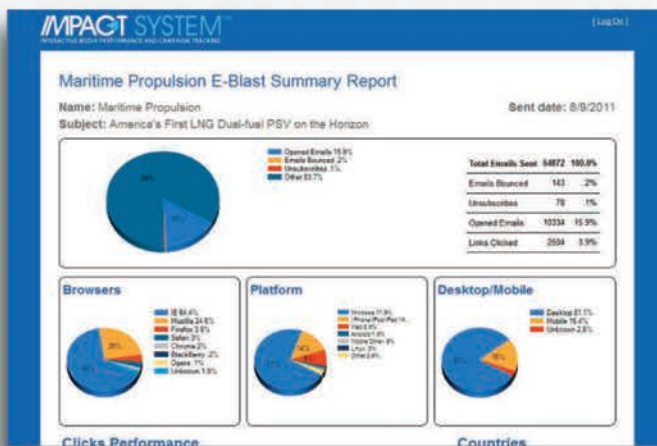

Online reports and response data:

- Browsers
- Platforms
- Desktop / Mobile
- Countries

Take control of your campaign-only from New Wave Media.

Track your banner ad exposure in real time, with an easy interface

Access a complete report of your Eblast campaign's success.

Impressions
 Clicks
 Click Through Rate
 Unique IPs

Total Emails Sent
 Opened Emails
 Links Clicked

Available for all online/email advertising programs, only from New Wave Media. For more information, contact your representative, or call our offices: (212) 477-6700

Lithium Ion Battery Fires: A Threat to Container Shipping

By Matthew Bonvento & Captain John Cox

From 2015 to present an estimated 250 incidents related to electric hoverboard fires have been recorded according to the United States Consumer Product Safety Commission. The same commission reports that 83,000 Toshiba laptop batteries were recalled in 2017 due to fire and safety concerns.

In January 2017 a NYC garbage truck was the source of a neighborhood surprise when a Lithium ion battery exploded in the compactor of the truck. Luckily no one was injured.

According to a study conducted by the National Fire Data Center branch of the U.S. Fire Administration, between January 2009 and 31 December 2016 a reported 195 incidents of E-Cigarette fires occurred in the U.S. 133 of these resulting in injuries.

What all these reports share, is that the underlying cause of each incident are lithium-ion batteries. Lithium Ion batteries have become an integral part of everyday life. Used in our computers, cell phones, cars, even e-cigarettes, there are very few electronic items that do not use these high-density batteries. The popularity is simple, better battery for a smaller size. According to the Australian Academy of Science, LI batteries are twice as strong as the traditional NiCad battery.

How do Lithium Ion batteries work?

According to the department of energy: “A battery is made up of an anode, cathode, separator, electrolyte, and two current collectors (positive and negative). The anode and cathode store the lithium. The electrolyte carries positively charged lithium ions from the anode to the cathode and vice versa through the separator. The movement of the lithium

ions creates free electrons in the anode which creates a charge at the positive current collector. The electrical current then flows from the current collector through a device being powered (cell phone, computer, etc.) to the negative current collector. The separator blocks the flow of electrons inside the battery.”

Why all the fires?

Lithium Ion batteries are subject to Thermal Runaway. This occurs when the separator blocking the flow of electrons in the battery fails.

Effects on the Shipping Industry

In a stunning fire on the 4th of January 2020 the COSCO Pacific suffered a container fire while underway from Nansha, China for Nhava Shevaby, India. The fire, although extinguished and no injuries were reported, the vessel was delayed several days as the extent of the damage was investigated.

The MY Kanga, in the port Dubrovnik, Croatia was a total loss when the vessel experienced a catastrophic fire. This fire was caused by a thermal runaway of several LI-on batteries in recreational vessels housed in the yacht garage. As the fire intensity increased, the crew and passengers were forced to abandon the vessel.

As the reader knows, at sea there are five different fire categories. A,B,C,D, and K. Lithium Ion batteries are primarily a Class D fire. The danger there being that they cannot be extinguished by means of water or smothering by CO₂. Class D fires burn hot enough to generate their own Oxygen. This means that they require a special means of extinguishing them.

Technology to the Rescue

Until recently there were only two ways to address a lithium battery fire. A firefighter could allow the electronic device to burn until all fuel is exhausted, or douse the burning device with large amounts of water. Both of these “solutions” have serious drawbacks. The damage of a fire to surrounding areas can be significant making the first option unacceptable. Additionally, fire on a ship, airplane or other confined area can become catastrophic. Extinguishing the fire is essential.

Dousing the fire with great quantities of water can reduce the temperature of the battery below the ignition point (180C/350F), however, the firefighter is in close proximity to the burning battery and the excess water can cause unanticipated damage to equipment and furnishings.

Recent innovation provides a new, more effective option. The necessity to reduce the temperature of a battery in thermal runaway, absorb the vapor (smoke, which is toxic) quickly is now available. The technological breakthrough is accomplished by the use of recycled glass beads that are specially designed to absorb heat and vapor. Tests show that a burning laptop is extinguished in 15 seconds. The method of application protects the firefighter.

This new technology is due to the efforts of CellBlock to help several industries cope with lithium battery fires. The CellBlock scientists realized that lithium battery fires were going to occur in growing numbers. Diverse sectors of the economy would be affected including manufacturing, airlines, healthcare and others. CellBlock engineers looking



© Graphic&Illustration/AdobeStock

at the transportation risks in the industry of lithium battery fires brought focus to the airlines (cargo and passenger), and now maritime.

Maritime's Risk

Our economy is global with goods are shipped worldwide, and within many of

those shipments are lithium batteries. The organization providing the shipping is at risk during the time the lithium batteries are onboard.

Having the ability to extinguish a battery entering thermal runaway quickly, before extensive damage occurs can be critical.

Two airlines have lost 747s to lithium battery fires. Each had over 50,000 batteries onboard and the source of ignition was traced to those containers. Ships carry millions of batteries. Having the ability to extinguish a lithium battery fire quickly could make the difference between an incident and a disaster.

The Author

Bonvento

Matthew Bonvento an Assistant Professor of Nautical Science. Previously he served as Senior Manager for Safety, Security, Regulatory, and Quality Compliance for Vanuatu Maritime Services Ltd. Additionally Mr. Bonvento is a licensing instructor in Long Island. Holding a Masters in International Transportation Management, and an Unlimited Chief Officers License as well as a 1600-ton Master license, he sailed for over 10 years prior to coming ashore. Matthew has dedicated himself to the advancement of safety and environmental awareness in the Maritime Industry.



The Author

Capt. Cox

Captain John Cox is the CEO of Safety Operating Systems. He is a 50-year aviation veteran with experience as a corporate pilot, airline pilot, instructor, test pilot and safety professional. He holds a MBA from Daniel Webster College, a graduate of the University of Southern California's Aviation Safety Program. For the last 10 years he has been the aviation analyst for NBC, MSNBC, CNBC and the Weather Channel. He regularly appears in the news media worldwide regarding aviation safety. Captain Cox also writes the weekly column "Ask the Captain" for USA Today's website.





**Business news you can
trust and advertising results
you can count on.**

**We have you covered
in every sector of
the industry.**

The Maritime Media Network's diverse portfolio of publications includes:
*Maritime Reporter & Engineering News,
Marine News, Marine Technology Reporter
and Offshore Engineer.*

Reaching a total average circulation of 125,584, these four publications reach decision makers all over the maritime industry, are audited by BPA, and are only available in the Maritime Network.

100% Requested
Circulation
Audited and Verified by BPA



June 2019 BPA

BUYER'S DIRECTORY

THIS DIRECTORY SECTION IS AN EDITORIAL FEATURE PUBLISHED IN EVERY ISSUE FOR THE CONVENIENCE OF THE READERS OF MARITIME REPORTER. A QUICK-REFERENCE READERS' GUIDE, IT INCLUDES THE NAMES AND ADDRESSES OF THE WORLD'S LEADING MANUFACTURERS AND SUPPLIERS OF ALL TYPES OF MARINE MACHINERY, EQUIPMENT, SUPPLIES AND SERVICES. A LISTING IS PROVIDED, AT NO COST FOR ONE YEAR IN ALL ISSUES, ONLY TO COMPANIES WITH CONTINUING ADVERTISING PROGRAMS IN THIS PUBLICATION, WHETHER AN ADVERTISEMENT APPEARS IN EVERY ISSUE OR NOT. BECAUSE IT IS AN EDITORIAL SERVICE, UNPAID AND NOT PART OF THE ADVERTISERS CONTRACT, MR ASSUMES NO RESPONSIBILITY FOR ERRORS. IF YOU ARE INTERESTED IN HAVING YOUR COMPANY LISTED IN THIS BUYER'S DIRECTORY SECTION, CONTACT MARK O'MALLEY AT MOALLEY@MARINELINK.COM

ANCHORS & CHAINS

Anchor Marine & Supply, INC., 6545 Lindbergh Houston, Texas 77087 , tel:(713) 644-1183, fax:(713) 644-1185, david@anchormarinehouston.com

APPROVED U.S. COAST GUARD MARINE SANITATION DEVICES

Environmental Marine, Inc., 711 Colyer Rd., Bronson, KY , USA , tel:(606) 561-4697, bobkenison@aol.com contact: Bob Kenison, www.envmar.com

CLEAN, QUIET, PROVEN: POWER & PROPULSION SOLUTIONS

BAE Systems, Bldg. 14, 1098 Clark Street Endicott, NY 13760 , tel:(607) 770-2083, carol.gorenflo@baesystems.com contact: Carol Gorenflo, www.GetToZero.com

COMMUNICATIONS

David Clark Company (Wireless Headset Communication Systems), 360 Franklin Street, Worcester, MA 77060, USA , tel:(800) 298-6235 , www.davidclarkcompany.com/marine

EXHAUST

Marine Exhaust Systems of Alabama, 757 Nichols Ave. Fairhope, Alabama 36532 , tel:(251) 928-1234, mark@mesamarine.com

FALL OVERBOARD PREVENTION AND RESCUE & RECOVERY

HARKEN, N15W24983 Bluemound Rd. Pewaukee, WI 53072, Pewaukee, WI , USA , tel:+1 262 691 3320, infoUSA@harkenindustrial.com, www.harkenindustrial.com

FIRE FIGHTING

Aussie Pumps, 7 Gladstone Road, Castle Hill , Australia , tel:+61 (2) 88653500, wlorenz@aussiepumps.com.au contact: Warwick Lorenz, www.aussiepumps.com.au

GET TO ZERO EMISSIONS

BAE Systems, Bldg. 14, 1098 Clark Street Endicott, NY 13760 , tel:(607) 770-2083, carol.gorenflo@baesystems.com contact: Carol Gorenflo, www.GetToZero.com

INERTIAL SENSING SYSTEMS

Silicon Sensing Systems Ltd, Clifftford Road Southway, Plymouth, Devon PL6 6DE United Kingdom , UK , tel:+44 (0) 1752 723330, sales@siliconsensing.com

MECHANICALLY ATTACHED FITTINGS (MAFS)

Viega LLC, 585 Interlocken Blvd. Broomfield, CO 80021 , tel:(316) 425-7400, mark.brodie@viega.us

MEMS MOTION SENSING

Silicon Sensing Systems Ltd, Clifftford Road Southway, Plymouth, Devon PL6 6DE United Kingdom , UK , tel:+44 (0) 1752 723330, sales@siliconsensing.com

METEOROLOGICAL INSTRUMENTS

R.M. Young Company, 2801 Aero Park Dr., Traverse City, MI , tel:231-946-3980, fax:231-946-4772, vsherman@youngusa.com

NAVAL ARCHITECTS, MARINE ENGINEERS

All American Marine, 1010 Hilton Ave. Bellingham, WA 98225 U.S.A. , tel:(360) 647-7602, marketing@allamericanmarine.com

Bristol Harbor Group, Inc., 103 Poppasquash Rd., Bristol, RI 02809, USA , tel:401-253-4318, fax:401-253-2329, design@bristolharbortgroup.com contact: Greg Beers, P.E. - President, www.bristolharbortgroup.com

The Shearer Group, Inc., 99 Poppasquash Road, Unit H, Bristol, RI , USA , tel:(401) 253-4318, fax:(401) 253-2329, gbeers@bristolharbortgroup.com

SHIP REPAIR, CONVERSION, REFIT, DRYDOCKING AND MAINTENANCE

Blohm+Voss B.V. & Co. KG, Hermann-Blohm-Strasse 3, 20457 Hamburg, Germany , tel:+49 40 3119 2110, shipservices@blohmvooss.com , www.blohmvooss.com

SURFACE PREP TOOLS

Water Cannon, 4300 West Lake Mary Blvd. Units 1010-424 , USA , tel:321-800-5763, sales@watercannon.com , www.watercannon.com

ULTRASONIC TRANSDUCERS

AIRMAR Technology Corporation, 35 Meadowbrook Dr., Milford, NH, USA, tel : , tel:(603) 249-7199, sales@airmar.com

VACUUM TOILET SYSTEM

Jets Vacuum AS, Myravegen 1 6060 Hareid , tel:47 700 39 100, fax:47 700 39 101, post@jets.no , www.jetsgroup.com

Promote a truly unique message with a Maritime Reporter TV interview.

With a Maritime Reporter TV interview, our editorial staff will work to develop insightful Q&A to educate and enlighten viewers about your company's latest advances, technologies and products. Interviews are conducted at events around the world and recorded, produced, and edited by the Maritime Reporter TV staff. The interview will be posted on marinelink.com and promoted to our highly engaged audience.

- Insightful Q&A with the editors of the industry's leading publication.
- Targeted marketing to the industry's largest online audience
- Optional social media boost to the industry's largest social media audience
- Includes all video production along with convenient and easy filming at the leading events around the world

To book a Maritime Reporter TV interview or for more information, contact your sales representative or call +1-212-477-6700.



www.MarineLink.com



MARKETPLACE

Employment

www.MaritimeJobs.com



MAXIMIZE YOUR POTENTIAL.

**Find your new career at:
MaritimeJobs.com**

www.MaritimeJobs.com

MARKETPLACE

Professional

www.MaritimeProfessional.com

Established in 1854



**CRANDALL
DRY DOCK ENGINEERS, INC.**

- Consulting • Design • Inspection
- Railway and Floating Dry Docks
- Dry Dock Hardware and Equipment

552 MacArthur Blvd. Bourne, MA 02532
(617)884-8420 • (888)DRY-DOCK
www.crandalldrydock.com

SPECIALISTS IN THE DESIGN OF:

- OFFSHORE SUPPORT VESSELS
- TUGS AND TOWBOATS
- BARGES
- HIGH SPEED CRAFT
- NAVAL VESSELS
- CREWBOATS
- SPECIAL PURPOSE VESSELS
- YACHTS



DESIGN, CONSULTING, SURVEYING AND DRAFTING SERVICES



GUARINO & COX, LLC
Naval Architects, Marine Designers and Consultants
19399 Helenberg Road Suite 203 Covington, LA 70433
Tel: (985) 871-9997 | Fax: (985) 871-9927
www.guarino-cox.com



LAY, PITMAN & ASSOCIATES, INC.
NAVAL ARCHITECTS

- Naval Architecture Services
- Marine Engineering
- Design Services
- Construction Administration
- Regulatory Liaison
- Inspections and Surveys

2300 Marsh Point Road #303
Neptune Beach, Florida 32266
(904) 221-7447
www.laypitman.com

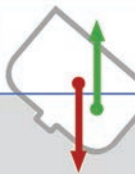

GHS
General HydroStatics

Software for Naval Architects
Stability | Strength | Seakeeping

- * Buoyancy, heel and trim in any condition
- * Longitudinal strength
- * Grounding and salvage simulations
- * Lifting and crane operations
- * Multi-body simulations and drydocking
- * Intact and damaged stability evaluations
- * Wind loads and multi-axis stability
- * Seakeeping and motion response
- * Onboard load monitoring

...and more!



Creative Systems, Inc.
P.O. Box 1910 Port Townsend, WA 98368 USA
+1 (360) 385-6212 | sales@ghsport.com
www.GHSPORT.com
For 48 years, the software that naval architects love.

HEGER DRY DOCK INC.
Marine Structural Engineers

Engineering for all types of drydocks

- Design
- Consultation (SME)
- Inspections/Certifications
- US Navy MIL-STD FCR
- Mooring Designs
- Caisson Gate Designs
- Appraisals
- Accident Investigations
- Drydocking Seminars



77 Main St., Suite 9,
Hopkinton, MA 01748
+1 (508) 429-1800
www.hegerdrydock.com

M.A.C.E.
FT. LAUDERDALE - USA
WORLDWIDE

Phone: (954) 563-7071
Fax: (954) 568-6598

- N.D.T Services
- Vibration - noise - structural/modal analysis
- Field balancing, Laser Alignment
- Torque - torsional vibration analysis
- IR - Thermography inspection
- Emmision tests, Engine Performance tests
- Low Location Light Testing



Herbert Engineering Corp.
**SHIP DESIGN &
ENGINEERING SERVICES**
Innovation • Analysis
• Optimization • BWTS
• Post - 2020 Fuel
• Safety • Efficiency
• Environmental Performance
510-814-9700 | www.herbert.com

GILBERT ASSOCIATES, INC.
Naval Architects
and Marine Engineers



100 Grossman Dr. Suite 205
Braintree, MA 02184
T: (781) 740-8193 • F: (781) 740-8197
E-mail: JGilbert@jwgainc.com
www.jwgainc.com



Naval Architects and Marine Engineers
Design and Analysis • FEA • CFD

119 Causeway Boulevard
New Orleans, LA 70121
504-218-8162 • www.minomarine.com

**MARITIME
PROPULSION**

Maritime Propulsion is the largest online database for marine power & propulsion equipment - the fastest way to find engine reports, specs, suppliers, and exclusive articles on industry developments.



www.maritimepropulsion.com

MARKETPLACE

Products & Services

www.MaritimeEquipment.com



SAFETY AT SEA

SafeEdge by Rustibus® is a manhole protection cover that prevents falls and other injuries associated with open manholes on-board vessels and platforms.

RUSTIBUS®
maintaining your values

rustibus.com | sales@rustibus.com

KIENE NOW OFFERS EUROPEAN-TYPE DIESEL ENGINE SAFETY AND INDICATOR VALVES . . .

Safety Valves

- Relieves excess pressure
- Protects engine
- Audible signal alerts engine personnel
- Available for most European engines

Indicator Valves

- Forged steel construction
- Accepts all common engine analyzers and indicators
- Sensor mounting models for continuous pressure measurement

Call or E-mail for info!

KIENE 1-800-264-5950
info@kienediesel.com
 DIESEL ACCESSORIES, INC. www.kienediesel.com



MARINE SALVAGE & FIREFIGHTING

2", 3" & 4" self-priming seawater pumps

- ☑ Huge flows to 1500 lpm
- ☑ Heads to 90m (128 psi)
- ☑ Yanmar 4.8HP diesel
- ☑ Bronze impeller/volute
- ☑ Corrosion resistant marine coating on casing
- ☑ Sacrificial anode
- ☑ Stainless steel fasteners

DESIGNED FOR A LIFE AT SEA

Aussie Pumps
aussiepumps.com.au
 +612 8865 3500

E4 POWER
Powerful, marine engineering solutions

Modular Exhaust System

Up to 70% lighter & 50% less labor cost

754-715-0818 Info@e4powerllc.com

BOLLARD™ MARINE GENERATORS

DESIGNED & BUILT FOR THE HARSH MARINE ENVIRONMENT

99kW

MANUFACTURED BY MER EQUIPMENT

WORLD ENERGY REPORTS

FPSOs • SEMIs • SPARs • TLPs
 FLNGs • FSRUs • FSOs

www.WorldEnergyReports.com

The industry's leading news site. Part of the world's largest maritime publishing network.

www.marinelink.com

BOLLARD

206.286.1817
 LOCATE A DEALER:
WWW.MEREQUIPMENT.COM

MARKETPLACE

Products & Services

www.MaritimeEquipment.com



www.mesamarine.com • marine.exhaust@gmail.com • 1-251-928-1234

Got Noise? HYDRAULIC SUPPRESSOR

Noise, Shock, Vibration & Pulsation in Quiet, Smooth Flow Out

Three Stage Noise & Pulsation in Reduction Chamber

QUALITY NACOL ACCUMULATORS

- Long Lasting, No Seam, Pleated Bladders
- Forged shells, no welds
- We stock 1/5 pint to 15 gallons in Chicago

(877) 534-6445
www.wilkesandmclean.com
info@wilkesandmclean.com

WILKES & MCLEAN, LTD.

IMPACT SYSTEM™

Interactive Media Performance and Campaign Tracking

Take control of your campaign—only from New Wave Media.

Give your online advertising real **IMPACT**—an exclusive tracking tool for online advertisers.

IMPACT platform displays data and traffic from:

- Browsers-Platforms Desktop / Mobile Countries
- Impressions / Clicks Click Through Rate Unique IPs
- Total Emails Sent Opened Emails Links Clicked

Track banner ad exposure in real time, with an easy interface

Access a complete report of your Eblast campaign's success.

Available for all online/email ad programs, only from New Wave Media. For details, contact your rep or call our offices: (212) 477-6700

Maritime Global News for iPhone and Android

FREE APP SCAN THE CODE TO DOWNLOAD

Vessels, Barges & Real Estate for Sale/Rent

List your maritime real estate here!
 Contact us today: +1 561-732-4368

ZIDELL MARINE CORPORATION

Specializing In Barges

- Single or Double Hull, Inland or Ocean-Going
- Chartering & Sales

Ask for Bill Gobel
 (503) 228-8691 • (800) 547-9259
 2020 SW 4th Ave Suite 600
 Portland, OR 97201

ADVERTISER INDEX

Page	Advertiser	Website	Phone#
19	.Anchor Maine & Supply, Inc	.www.anchormarinehouston.com	.(800) 233-8014
47	.Carver Pump	.www.carverpump.com	.(563) 263-3410
11	.Click Bond, Inc.	.www.clickbond.com/MR4	.(775) 885-8000
25	.CR Ocean Engineering LLC	.www.croceanx.com	.(973) 455-0005
35	.E4 Power LLC	.www.e4powerllc.com	.(754) 715-0818
3	.MAN Energy Solutions SE	.www.pbst.eu	.Please visit us online
27	.Offshore Wind Power	.www.worldenergyreports.com/wind	.(212) 477-6700
15	.Omnithruster	.www.omnithruster.com	.(330) 963-6310
C4	.Pacific Green Marine Technologies	.www.pacificgreenmarine.com	.44 203 988 2897
1	.SMM 2020	.www.smm-hamburg.com	.Please visit us online
23	.SPBES	.www.spbes.com	.(778) 819-1898
C2	.Thordon Bearings inc	.www.ThordonBearings.com	.Please visit our website
13	.W&O Supply	.www.wosupply.com	.(904) 354-3800
C3	.World Energy Reports	.www.worldenergyreports.com	.(212) 477-6944



PRINT AND DIGITAL FEATURED CONTENT

A MULTI-PLATFORM MARKETING SOLUTION

LEVERAGE THE FULL POWER OF THE MARITIME MEDIA NETWORK WITH A FEATURED CONTENT PACKAGE

A multi-platform featured content package is a great way to build brand awareness to the industry's largest verified circulation - in print and digital! With this powerful marketing tool, a professional marine industry writer will help you to create an effective message and communicate it to the global maritime industry. Your message will be seen by decision-makers, purchasers and buyers through various media platforms and websites.

For pricing or to learn how *Maritime Reporter & Engineering News* and the Maritime Network can help build brand awareness across multiple platforms, contact your sales representative today, or call **+1-212-477-6700**.

*The listings above are an editorial service provided for the convenience of our readers.
If you are an advertiser and would like to update or modify any of the above information, please contact: productionmanager@marinelink.com*



The industry's most sophisticated and in-depth Floating Production Systems market intelligence, business outlook and interactive database.

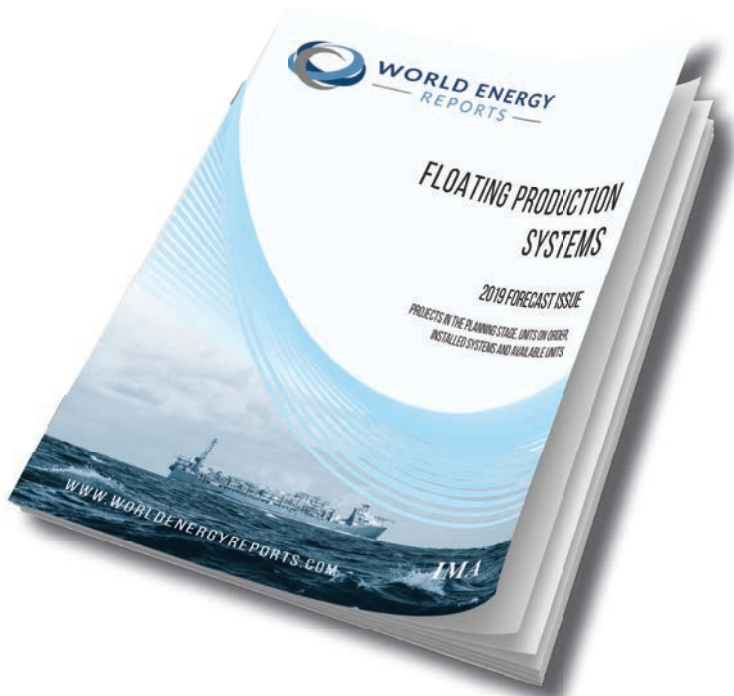

Our Market Intelligence Suite Includes:

- Full industry intelligence covering: FPSOs, SEMIs, SPARs, TLPs, FLNGs, FSRUs & FPSOs
- Annual five-year market forecast
- Real time, interactive online database
- Monthly reports and forecast recalibration
- Customer support and research assistance

ACTIVATE YOUR FREE REPORT TODAY:
www.worldenergyreports.com

World Energy Reports:
+1-212-477-6944

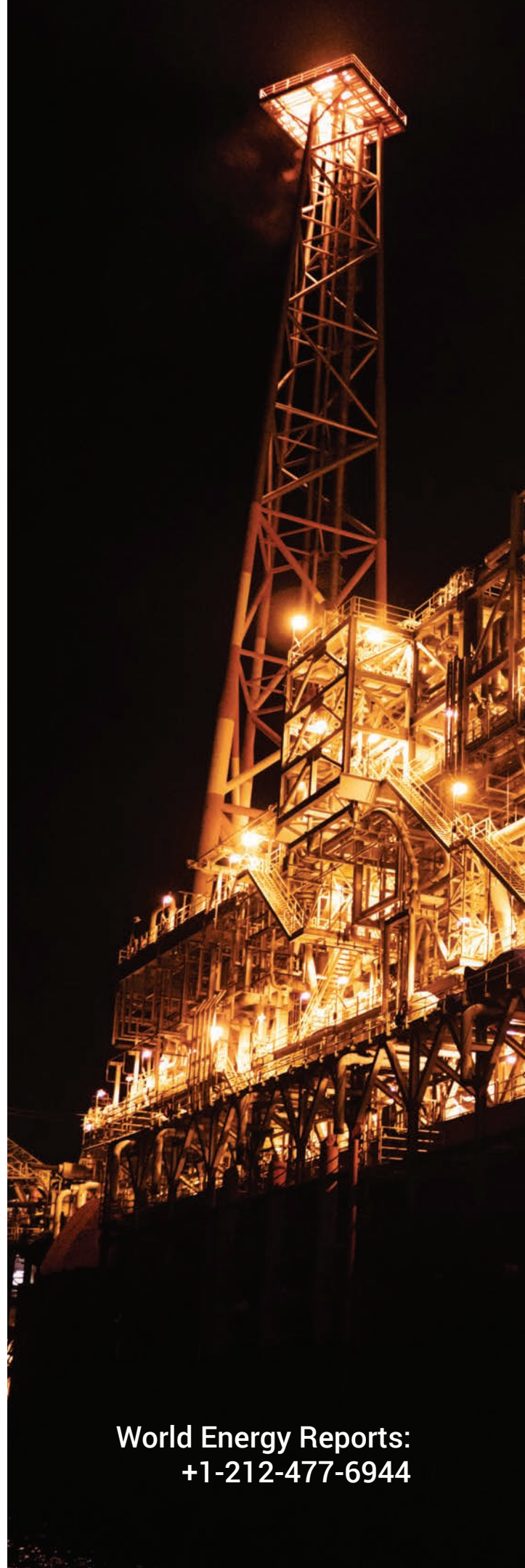



PacificGreen

Marine Technologies

Introducing the new Vectra model for newbuilds or retrofit.

Game changing scrubber technology.

ENVI-Marine™ V

Optimized structural design leading to lower maintenance and longer life

Lower back pressure due to geometry optimization

Reduction in scrubber weight

Lower cost

One of the smallest most flexible footprints on the market, combined with high quality swift installation and world beating device efficiency are just some of the reasons why more and more ship operators are choosing Pacific Green.



Watch a video to see how it works



www.pacificgreenmarine.com

Contact our team at +44 203 988 2897 or email marine-enquiries@pacificgreen.tv



Part of the Pacific Green Technologies Group