

Marine

News

JUNE 2011

WWW.MARINELINK.COM

The Leadership Edition



Stark



Calhoun



Witte



Eckstein



Jones



Crowley

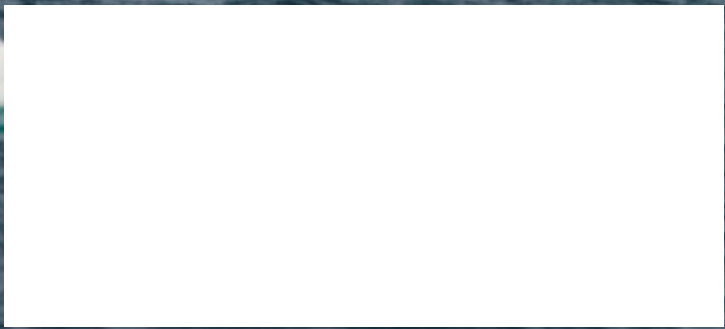

Insights
Michael Hume, W&O Supply
page 8



Offshore
Veolia Grows its Business
page 42



KVH® INDUSTRIES
MINI-VSAT
BROADBAND

Airtime Plans starting at
50 MB for \$49!

Game changer.

{ **game changer** /gáym•cháyner/ *n.* 1. something that completely re-defines the sector in which it competes. }

Fast.

Download speeds
as fast as 2 Mbps

Affordable.

Low-cost hardware with
airtime you can afford
to use! Data: \$0.99/MB
Voice: \$0.49/minute

Global.

Worldwide mini-VSAT
Broadband network with
seamless roaming

Simple.

An end-to-end SATCOM
solution, all from KVH

Small.

Easy to install system
with ultra-compact 15.5"
(39 cm) diameter dome



Until today, SATCOM services at sea cost a small fortune. Either the hardware was too big, too complicated or too expensive, or the airtime would bust your budget. Not anymore. The remarkable KVH TracPhone® V3 is changing all the rules.

www.kvh.com/v3

The Next Generation in Marine SATCOM, Here Today!

KVH



KVH Industries, Inc.
Middletown, RI U.S.A.
Tel: +1 401 847 3327
Fax: +1 401 845 8190
E-mail: info@kvh.com

KVH Europe A/S
Kokkedal, Denmark
Tel: +45 45 160 180
Fax: +45 45 160 181
E-mail: info@kvh.dk

KVH Norway AS
Horten, Norway
Tel: +47 33 03 05 30
Fax: +47 33 03 05 31
E-mail: infokvhnorway@kvh.com

KVH Singapore
Singapore
Tel: +65 6829 2343
Fax: +65 6829 2121
E-mail: infokvhsingapore@kvh.com

POWER



Kvichak Marine Industries



*Scania engines - 12 or 16 liter
with ratings from 300 to 800 hp*

Power to propel both vessels and business.

Since 1902, commercial mariners around the world have relied on Scania engines to power their fishing boats, patrol boats, tug boats and ferries. No matter the application, Scania marine engines have earned a reputation for their robust performance, legendary durability and outstanding fuel economy.

Read more at www.scaniausa.com



SCANIA

Scania U.S.A. Inc.

Scania U.S.A., Inc. • San Antonio, TX • Phone 210.403.0007 • Fax 210.403.0211

E-mail: contact@scaniausainc.com • Web site: www.scaniausa.com

DISTRIBUTORS

Northeast/Great Lakes
Mack Boring & Parts Co.
908-964-0700

Northwest
Cascade Engine Center
206-764-3850

Southeast/Gulf Coast
Certified Diesel
954-583-4465

Southwest
Boatswain's Locker
949-642-6800

Central/Eastern Canada
ADF Diesel
800-517-1489



U.S. Coast Guard photograph by Petty Officer 3rd Class Mario Romero.

USCG Buoy Tender during a pollution response drill in Galveston Bay.



Photo: Crowley Maritime

Tom Crowley, Jr., Chairman & CEO, Crowley Maritime Corp.

8 **Insights**
Michael Hume
 President & CEO, W&O Supply

12 **Tech File**
The Scuderi Prototype
 Gasoline engine prototype

14 **Boat of the Month**
Trawling for Scrap Metal

47 **Blogs @ MaritimeProfessional.com**
Hearing on Maritime Jobs
 U.S. maritime stakeholders slighted by government ... again. — by Joseph Keefe

24 **Cover Story**
The Leadership Edition

In this Leadership Edition of *MarineNews* we bring you a line up of executives with insights on market conditions, legislation and business strategies for the coastal and inland waterways and salvage fields. Leaders offer an insiders view on major factors impacting the industry, and include:

- **Rick Calhoun**, Chairman, Waterways Council, Inc.,
- **Tom Crowley, Jr.**, Chairman & CEO, Crowley Maritime Corporation
- **John Eckstein**, Chairman, President & CEO, Marquette Marine Transportation
- **Charles Jones**, Chairman of the Board, AmherstMadison
- **James Parker**, GM, Offshore Division, Veolia
- **James Stark**, Executive Director for the Gulf Intracoastal Canal Association
- **John Arnold Witte, Jr.**, Executive Vice President, DonJon



DELTAWAVE

COMMUNICATIONS, LLC.

If you ever find yourself lost...

...don't panic.

The new pocket sized Shout Nano provides global two-way messaging and pinpoint GPS accuracy. When used with our dTrac mapping service, we've got you covered. It can also be used with our new optional Global Rescue Services!



"Delta Wave is also a Service Provider offering a comprehensive line of Iridium and Inmarsat mobile satellite products and airtime services."

866-650-9283 / email: sales@deltawavecomm.com

www.deltawavecomm.com

MarineNews

ISSN#1087-3864 USPS#013-952

Florida: 215 NW 3rd St., Boynton Beach, FL 33435
tel: (561) 732-4368; fax: (561) 732-6984

New York: 118 E. 25th St., New York, NY 10010
tel: (212) 477-6700; fax: (212) 254-6271

www.marinelink.com

PUBLISHER

John C. O'Malley • jomalley@marinelink.com

Associate Publisher & Editor

Greg Trauthwein • trauthwein@marinelink.com

Managing Editor

Raina Clark • rainaclark@marinelink.com

Contributing Writers

Lawrence R. DeMarca, III • Frederick B. Goldsmith • Matt Gresham •
Randy O'Neill • Jim Shirley

PRODUCTION

Production Manager Irina Tabakina • tabakina@marinelink.com

SALES

Vice President, Sales & Marketing

Rob Howard • howard@marinelink.com

Sales Administration & Office Manager Rhoda Morgan • morgan@marinelink.com
Sales & Event Coordinator Michelle Howard • mhoward@marinelink.com
Classified Sales Manager Dale Barnett • barnett@marinelink.com
tel: 212-477-6700

Advertising Sales Managers

National Sales Manager

Jack Bond • bond@marinelink.com

Tel: 561-732-1659 Fax: 561-732-8063

Lucia Annunziata • annunziata@marinelink.com Terry Breese • breese@marinelink.com
Tel: 212-477-6700 Fax: 212-254-6271 Tel: 561-732-1185 Fax: 561-732-8414

Tristan McDermott • mcdermott@marinelink.com Dawn Trauthwein • dtrauthwein@marinelink.com
Tel: 561-732-0312 Fax: 561-732-9670 Tel: 631-472-2715 Fax: 631-868-3575

Mike Kozlowski • kozlowski@marinelink.com
Tel: 561-733-2477 Fax: 561-732-9670

Managing Director, Intl. Sales

Paul Barrett • ieaco@aol.com

Tel: +44 1268 711560 Fax: +44 1268 711567

Uwe Riemeyer • riemeyer@intermediapartners.de

Tel: +49 202 27169 0 Fax: +49 202 27169 20

CORPORATE STAFF

Manager, Accounting Services Rhoda Morgan • morgan@marinelink.com
Manager, Public Relations Mark O'Malley • momalley@marinelink.com
Manager, Marketing Jocelyn Redfern • jredfern@marinelink.com
Manager, Info Tech Services Vladimir Bibik • bibik@marinelink.com

CIRCULATION

Circulation Manager Kathleen Hickey • mncirc@marinelink.com

TO SUBSCRIBE:

Subscriptions to **Marine News** (12 issues per year) for one year are available for \$49.00;

Two years (24 issues) for \$64.00.

Send your check payable to:

MarineNews, 118 E. 25th St., New York, NY 10010.

For more information call Rhoda Morgan at:

(212) 477-6700; fax: (212) 254-6271; morgan@marinelink.com

POSTMASTER Time Value Expedite



On the Cover Leading the Way

MarineNews is again honored to serve as the forum for industry leading executives to air their views on the industry's direction. See full story starting on page 24



Salvage

16 Marine Casualty Response

By Jim Shirley

Legal

18 ABCs of MSAs

By Lawrence R. DeMarca, III

Finance

21 Marine Finance "101"

By Richard J. Paine, Sr.

- 44 Vessels
- 46 Markets: Communications
- 48 People & Company News
- 52 Products
- 54 Directory: Ship & Boayards
- 57 By the Numbers
- 58 Classifieds
- 64 Ad Index

MarineNews ISSN#1087-3864 is published monthly, 12 times a year by Maritime Activity Reports, Inc., 118 East 25th Street, New York, N.Y. 10160-1062. The publisher assumes no responsibility for any misprints or claims and actions taken by advertisers. The publisher reserves the right to refuse any advertising. Contents of this publication either in whole or in part may not be reproduced without the express permission of the publisher.

POSTMASTER: Send address changes to **MarineNews**, 118 East 25th Street, New York, N.Y. 10160-1062.

MarineNews is published monthly by Maritime Activity Reports Inc. Periodicals Postage paid at New York, NY and additional mailing offices.

Radome Environmental Control Unit

Keep Your Equipment Cool

Dometic
MARINE

Conveniently small, lightweight and easy to install, the **Radome ECU** is designed to exceed the cooling requirements of pleasure boat, commercial vessel, and military ship applications. Rugged construction with corrosion-resistant materials allows the unit to be operated in the most extreme conditions at sea. It's highly efficient yet powerful rotary compressor provides quieter operation, increased reliability, and reduced amperage.



Self-contained
HSA16KCZ/1-417A shown

The Radome ECU is available in three configurations:

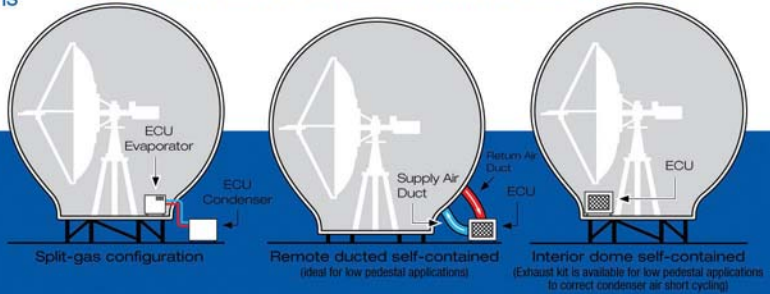

2301 NASA Parkway, Seabrook,
TX 77586 USA
Toll Free: 1.800.767.7606
Fax: 281.474.2714
Email: sales@aersupply.com
www.aersupply.com

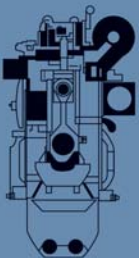

GLOBAL MARINE POWER, LLC

MARINE ENGINES • POWERPLANTS • TURBOCHARGERS

GLOBAL MARINE POWER, LLC • 6720 C MAYFAIR ST, HOUSTON, TX 77087 USA
+1(713)640-9300(TEL) • +1(713)640-9302(FAX)
WWW.GLOBALMARINEPOWER.COM

Global Marine Power, LLC carries quality equipment at competitive prices. We assure you of our business services without compromising on quality and time. Global Marine Power, LLC undertakes complete repair and annual maintenance contracts. We also provide consulting services to power plants.

MARINE ENGINES – 2 & 4 STROKE
– MAIN & AUXILIARY ENGINES & SPARES
POWER PLANTS
GENERATORS
SEPARATORS
COMPRESSORS & REFRIGERATION
ANCHORS & ANCHOR CHAINS



"We specialize in Bergen - Normo and Wärtsilä Engines/Spares"

June is *MarineNews*' Leadership Edition in which we speak with a number of executives from a range of maritime businesses in the North American shallow draft market. Leading businessmen in the inland river, coastal tug and barge, offshore support and salvage markets offer valuable insights on things such as the economic climate, how potential legislation and ongoing regulations impact business, infrastructure issues weighing heavy on the industry, the rate of permitting for offshore drilling and how it effects their work and even how the recent flooding on the rivers threatens business.



Markets are still depressed, most of these leaders confirm. Reduced demand for goods and the cost of fuel both contribute to that. With so many vessels to be had, rates are unlikely to go up very soon. But major players like Crowley Maritime say they are still able to keep their assets employed and they continue to upgrade their fleets. Crowley Maritime just christened two new double-hulled petroleum tank barges and said they are the first double-hulled, environmentally friendly barges of their kind to operate in Western Alaska

In the offshore arena, the pace of permitting for drilling still leaves many in the industry frustrated. President Obama affirmed a need to get moving on drilling, seemingly swayed by an outcry over prices at the pump. On the first of June, the Bureau of Ocean Energy Management, Regulation and Enforcement (BOEMRE) approved the 15th permit for a deepwater well, "for those of you who are counting," the press release said. That brings us up to about the half-way point, if we're on our way to returning to pre-moratorium permit levels.

On the inland waterways, Marquette Transportation's Chairman, President and CEO, John Eckstein, reported that between the coal and agricultural commodity outlooks, he was feeling very good about the recovery. Unfortunately the flooding has hampered that, but still, he said he felt bullish for the long-term.

A handwritten signature in black ink that reads "Raina Clark". The signature is fluid and cursive.

Raina Clark, Managing Editor, rainaclark@marinelink.com

Want to hear more from behind the editor's desk? [Visit the MarineNews Notes blog at www.MaritimeProfessional.com](http://www.MaritimeProfessional.com).

Online Resources

SUBSCRIBE

Subscribe to the print or electronic edition of *MarineNews* at www.marinelink.com/renewsubscr/Renew04/subscribe.html or e-mail Kathleen Hickey at mrcirc@marinelink.com

DAILY NEWS via E-MAIL

Twice every business day we provide breaking news, tailored to your specification, delivered FREE directly to your e-mail. To subscribe visit <http://maritimetoday.com/login.aspx>

POST & SEARCH JOBS

Job listings are updated daily and help match employers with qualified employees. Post a position or keep abreast of new employment opportunities at <http://www.maritimejobs.com>

ADVERTISE

MN offers a number of print and electronic advertising packages. To see our editorial calendar and advertising rates, visit www.marinelink.com/AdvRates/Rates.asp



Innovation Drives Efficiency

When complex projects demand competitive cost and on-time delivery, look to Signal International. We recently completed two of the world's largest floating power generation barges within a 180-day time frame at our state-of-the-art continuous-flow manufacturing facility.

We are consistently recognized by the Shipbuilder's Council of America as one of the safest shipyards in the United States. Signal specializes in new construction, repair, and conversion of ships, rigs, specialty barges, modules for refinery expansion and renewable energy components for wind and wave with facilities in Mobile, AL, Pascagoula, MS, Orange and Port Arthur, TX.

Call today to see how we can fast-track your next project.

For more information or facility tour

Joe Roche – Drilling Rigs +1.281-899-2121 ■ Rob Busby – New Construction +1.713.557.4517 ■ Joe Mayhall – Ship Repair and Dry-Docking +1.251.544.2627

Signal Ship Repair



... a division of Signal International

Maximizing your investment.

www.signalinternational.com

SIGNAL

INTERNATIONAL
A Marine & Fabrication Company

NEW CONSTRUCTION ■ SHIP REPAIR ■ Conversion ■ DRILLING RIGS ■ SHIPS ■ BARGES ■ WORKBOATS ■ HEAVY FABRICATION

MOBILE AL

PASCAGOULA MS

ORANGE TX

President and CEO of W&O Supply

Michael Hume

MarineNews spoke with Michael Hume, W&O Supply's new President & CEO. Hume describes his background in the industry, and the market his company serves, and offers insights into how W&O has achieved its business success.

What is your professional background and how did it lead to your current position as CEO of W&O?

I started my career in the financial industry as a commercial loan officer, meeting daily with business owners of small to large companies and analyzing their financial situation to fund their endeavors. Enjoying that experience is what has guided me throughout my career, leading me to reach my goal of running a company. My experience in the maritime industry started with W&O almost 20 years ago. Given my business background, I was hired by the company's founder to run the Long Beach, Calif. office in order to learn the business from the ground up. I have since taken on increasingly larger areas of responsibility as W&O has grown. Over the years, I've absorbed myself in our industry, and by combining the knowledge I've acquired and the specific expertise of our employees, we have continued to achieve success as a company. Serving as CEO allows me to have a pulse on the industry and drive our overall business operations to achieve our goals for the future. It excites me to be able to bring all of those elements together in leading W&O towards a successful future.

Can you describe the market W&O serves?

At its core, W&O is a provider of pipe, valves, fittings, engineered products and automated valve systems for the marine and marine-offshore industries. We have evolved into more of a partner in the development and execution of projects, helping to create customized solutions for various shipboard applications. This has created many opportunities for us as we've integrated ourselves more into our customers' daily operations. We are at a point where we are helping ship owners/operators and shipyards by designing and installing custom solutions that manage costs, improve their bottom line, navigate regulatory compliance and address product issues and other challenges



Images courtesy W&O

they are facing. Right now, our industry is facing a lot of regulatory uncertainty regarding fuel, emissions, ballast water and others. Those challenges combined with decreased funding for government projects, implementing new technology and the drilling moratorium in the Gulf of Mexico has created a volatile environment for our customers to conduct business. By stepping in and serving as a partner in addressing each customer's specific challenges and needs, we have created many opportunities for growth for W&O, as this approach has resonated with our customer base.

**THERE'S ONLY ONE SSC TEAM THAT IS READY TO ROLL OUT.
IMMEDIATELY.**

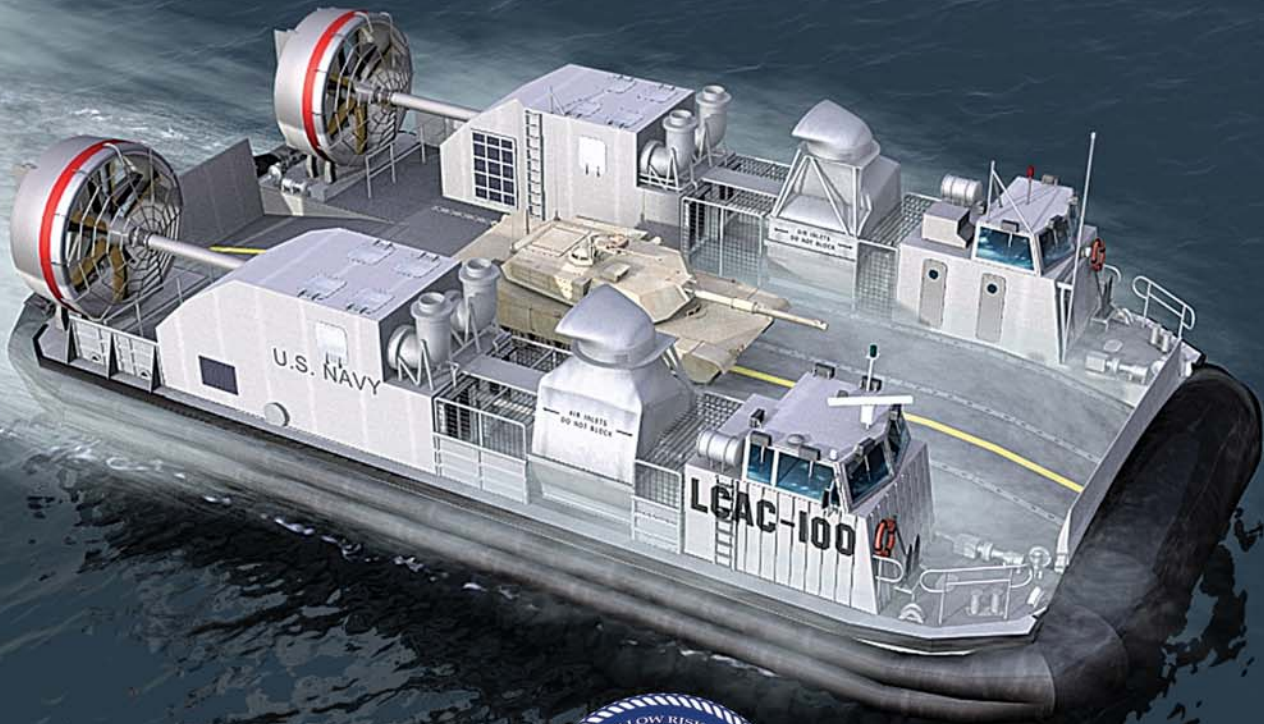

Use of this image does not imply or constitute U.S. DoD endorsement.

TEAM TEXTRON HAS THE KNOWLEDGE, EXPERIENCE AND EXPERTISE TO DO THE SHIP-TO-SHORE CONNECTOR JOB RIGHT — RIGHT NOW.

- Advanced maritime integration capabilities
- Technical expertise and proven, high-rate precision manufacturing
- Craft command module built around an existing maritime open-architecture systems integration lab
- Years of experience building and upgrading LCACs to enhance functionality and lower costs
- Innovative aluminum structural design engineering and assured material supply
- A wide range of manufacturing capabilities, equipment, value stream mapping and buoyancy box building

To find out more about why Team Textron has what it takes to provide the lowest-risk, best-value SSC solution for the U.S. Navy, visit www.LowRiskSSC.com



TEXTRON Marine & Land Systems



INSIGHTS

“Right now, our industry is facing a lot of regulatory uncertainty regarding fuel, emissions, ballast water and others. Those challenges combined with decreased funding for government projects, implementing new technology and the drilling moratorium in the Gulf of Mexico has created a volatile environment for our customers to conduct business.”

• *Michael Hume, President & CEO, W&O Supply*

What are the latest technological advances in your market?

The latest technological advances in our industry and those most relevant to customers' needs address efficiency, optimization and changes in regulations. For example, W&O has developed iShip, a combination of technological applications that focus on these needs and save our customers time and money. One component of iShip is FuelProof, a fuel measurement and optimization system that accurately measures bunkering, engine efficiency and emissions monitoring — offering substantial improvements over previous methods used by the industry. FuelProof is already proving to be very successful in optimizing operations by controlling costs and ensuring accuracy in bunkering and engine-efficiency measurements. Solutions such as iShip and FuelProof are what our industry needs: a straightforward solution that provides interaction and transparency to all shipboard systems with an excellent ROI.

To what do you attribute the success W&O has enjoyed?

W&O's success stems from several areas, all of which receive equal dedication from our employees and our leadership team. First, our success comes from being laser-focused on the marine and marine-offshore industries. We set our sights on understanding each customer's particular needs and in developing strong relationships with each customer. Developing these partnerships and understanding the inherently critical nature of the marine business has been another pivotal element of our success. Second, the technical expertise of our employees is a strategic advantage; our employees are talented, motivated and educated in both piping systems and the marine industry in general. They utilize each of these attributes to help our customers navigate market challenges. Our employees are



Images courtesy W&O

W&O's iShip FuelProof bunker meter measures factors affecting the bunkering process, including mass, density and temperature, among others, to provide ship owners/operators with a reading of 0.5% of total custody transfer flow.

heavily immersed in all aspects of the industry, giving them the expertise they need, when they need it — which benefits our customers. Finally, our global footprint has positioned us very well to service the increasingly global marine industry, as many of our customers are expanding internationally as well. We have 18 domestic and international branch locations, and while we have plans to establish even more in the future, our current distribution and service network extends to all corners of the globe. We can have people and/or products available anywhere, anytime they are needed.

How is W&O investing in the future?

W&O's continual investment in talent and technology will pave the way for success into the future. We are always looking ahead to develop solutions for industry challenges, and it's our employees, vendor partnerships and leadership team that will continue to make this happen. Knowing that our industry is becoming increasingly global is key to our future as well and we are evaluating opportunities to expand our branch network into Brazil, Southeast Asia, Europe and the Middle East. Seeking out and appropriately managing customer accounts around the world necessitates our expansion, which we are investing in heavily. While organic growth continues to climb, we are also always keeping an eye on possible acquisitions. Companies that bring an added-value element to our existing business by providing technical equipment and service capabilities to a ship-board application are attractive targets. Growth through acquisition and creatively expanding our organic business are how we've become the W&O we are today: one that is successful, responsive to market needs, reputable in the industry and proud of its employee culture.

www.marinelink.com

JRC FleetBroadband Power Duo

Quality voice and high-speed data

Proven antenna design

Single coax installation

Dedicated compact solution

JUE-250



JRC Launch IT



JRC Launcher is a dedicated user interface

allowing full configuration of the FleetBroadband systems

JUE-500



Option Interface Unit (OIU)

Available for the JUE-500, this add-on system is packed with a range of additional features.



Feel connected. Communicate further.



Since 1915

JRC Americas
(206) 654-5644

www.jrcamerica.com

Firing After Top Dead Center

The Scuderi Prototype

The Scuderi Engine Prototype I is the first proof-of-concept prototype for the Scuderi Split-Cycle Engine which claims to increase power, decrease engine size and reduce fuel consumption. This one-liter, naturally aspirated two-cylinder gasoline engine is the first of several prototypes under development by the Scuderi Group (based in West Springfield, Mass). The turbocharged and air-hybrid gasoline engine prototypes are forthcoming and will be followed by the diesel versions. Scuderi has targeted the automotive industry to begin with, but says the engine is also well suited for the marine applications.

The engine utilizes a unique combustion process referred to as “firing after top dead center.” According to the Scuderi Group, this produces a highly efficient and clean-burning combustion process. When firing after top dead center, combustion starts between 11 and 15 degrees after top dead center and ends 23 degrees after ignition. This results in a higher average combustion cylinder temperature but a lower peak temperature than conventional engines. The Scuderi Engine divides the four strokes of a

combustion cycle between two paired cylinders — the left cylinder functions as an air compressor, handling intake and compression, while the right cylinder handles combustion and exhaust. Key to Scuderi’s split-cycle design is its compression of the air before it fires. By optimizing the split-cycle concept, Scuderi says the fully developed engine will reduce NOx emissions up to 80% and improve fuel efficiency by 50%, compared to a conventional gasoline engine. The engine requires one crankshaft revolution to complete a single combustion cycle and is projected by the Scuderi Group to have higher torque and thermodynamic efficiency and lower emissions than today’s engines. The Scuderi Group says the new engine design, when boosted with a turbocharger to 3.2 bar, decreases the brake specific fuel consumption (BSFC) up to 14% as a simultaneous increase occurs in the engine’s power brake mean effective pressure (BMEP) by 140%. At the same time the engine can be reduced in size by roughly 29%.

Consistent with conventional four-stroke engine

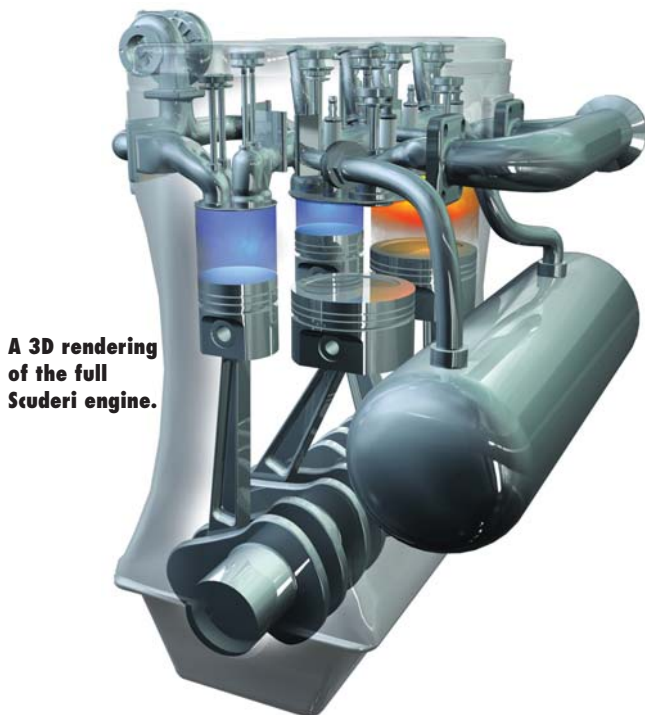

A 3D rendering of the full Scuderi engine.

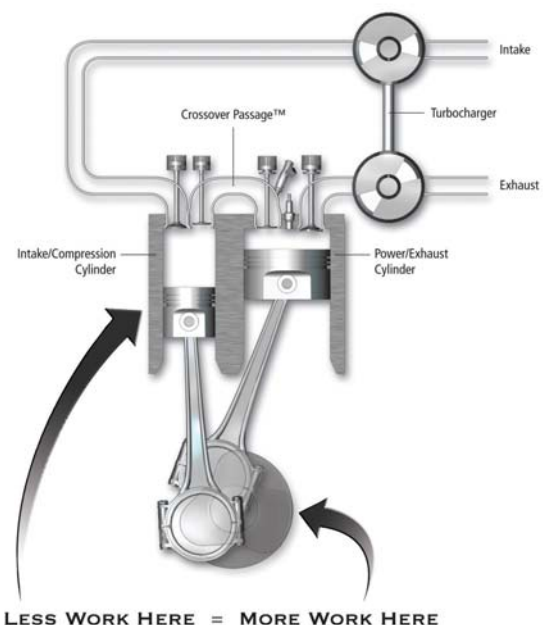

A schematic of the Scuderi/Miller integration,

designs, the combustion cycle of the Scuderi Engine has two high-pressure strokes — compression and power, and two low-pressure strokes — intake and exhaust. The power stroke is positive work, or the energy that is produced by the expanding gases to create mechanical work. The intake, compression and exhaust strokes are all negative work, or the energy that the engine consumes to create mechanical work. By separating the compression cylinder from the power cylinder and by using a standard turbocharger to convert recovered exhaust-gas energy into compressed air energy, the size of the compression cylinder can be downsized to achieve substantial reductions in negative compression work.

“The Scuderi Engine gains a massive advantage from turbocharging, Miller-like valve control strategies and extended expansion that is simply not possible with conventional engine designs,” said President of Scuderi Group, Sal Scuderi. “The net result is a smaller, higher-performing engine that yields significant gains in volumetric efficiency and power as well as reducing BSFC.”

Other highlights of the engine prototype include a high resistance to knock due to the continuous high-pressure air flowing through the crossover passage and the injection of fuel late in the combustion process; a custom-designed fuel injection system by Bosch; prevention of trapped fuel in the crossover passage by a high-pressure, direct-injection type fuel injector and a uniquely designed crossover passage; higher efficiency at part-load demand because of a unique valve train design utilizing pneumatic, fully variable valves to control engine load; and internally generated air to run the intake and exhaust valves and pneumatic springs for the high-speed crossover valve.

www.ScuderiEngine.com

www.marinelink.com

em-trak



Port Supply Exclusive!

Affordable Class A AIS- See and be Seen

The em-trak A-100 adds a new level of safety and convenience to any vessel by allowing the transmission of AIS positional data between you and other AIS equipped vessels.



- Real time navigational awareness no matter what gets in your way
- Dramatically improves operational efficiency and reduces resource costs by having the ability to see a fleet of vessels and use that control to task manage and prioritize.
- Compact size and cutting edge design means easy installation on any vessel
- Internationally certified to the highest standards including U.S. Coast Guard and FCC approval
- Simple to interface with all other on board navigational equipment and displays
- Peace of mind with a two year manufacturer's warranty with extension options from Port Supply

 **Port Supply**

The Wholesale Division of  **West Marine**

Call: 1-800-621-6885 • Online: portsupply.com

Email: govtind@portsupply.com

Over 300 West Marine locations to serve you

BOAT OF THE MONTH

Trawling for Scrap Metal

It looks like a typical Gulf of Mexico double-rigged shrimp trawler. However at 110 ft by 28 ft she will be bigger than most shrimpers. Like her sister, the Poncho, delivered in 2009, the new vessel is also built with robust framing and extra power. Like the Poncho, the as yet unnamed vessel, will be trawling for scrap metal, old tires and any other scrap at the site of a decommissioned oil rig. The work, mandated by U.S. Mineral Management Services in 1990, requires the site to be cleaned to the point that it can be safely trawled by typical Gulf shrimp gear. To get the site to this level of cleanliness the vessel owners, B & J Martin, use their proprietary Gorilla Net. The gear employs a weave of 3/4-inch combination cable at the opening with a body made of twine five-times the strength of a standard trawl net. The boat tows two of

these 80-ft nets each capable of recovering up to six tons of waste. To manage a “catch” of this magnitude requires a lot of power. For this work, a pair of Cummins K38-M EPA Tier II certified engines turning into Twin Disc #MGX-5321 gears, with 5.96:1 ratios, power the boat. As installed in the new vessel these engines are each rated for 850 hp at 1,800 rpm. Deck winches include a CME Model 2FH-505-038-579 double drum hydraulic as well as a CME Model 1A11-100A3-1-00 single drum hydraulic anchor winch. The boat, designed by Joseph Rodriguez and built by Rodriguez Boat Builders, has a 3,000 cubic ft hold capacity. Tankage is provided for 30,000 gallons of fuel in seven separate tanks. Another three tanks hold up to 8,000 gallons of water, while two more tanks hold up to 750 gallons of lube oil.

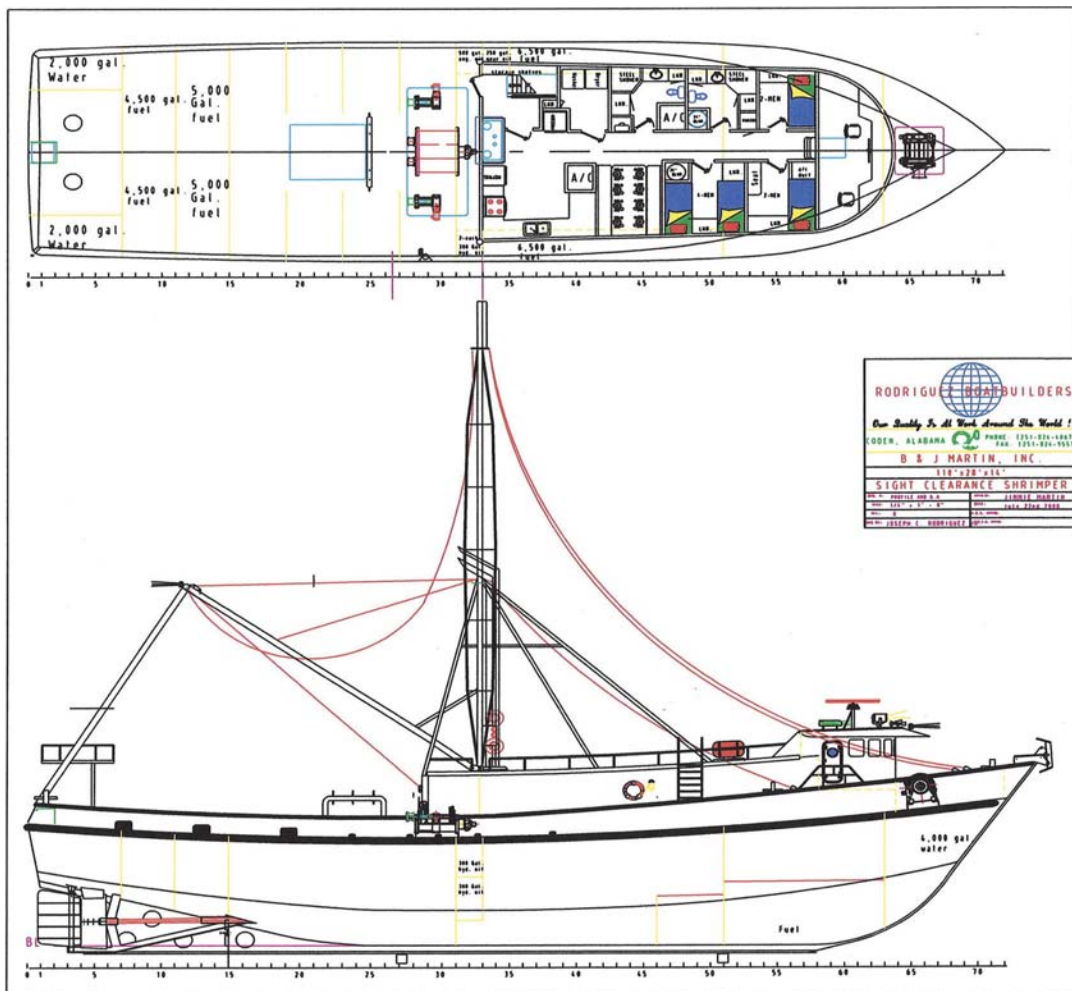

Drawing courtesy of Rodriguez Boat Builders

FEATURES

Non-Pollution Air Sealing System

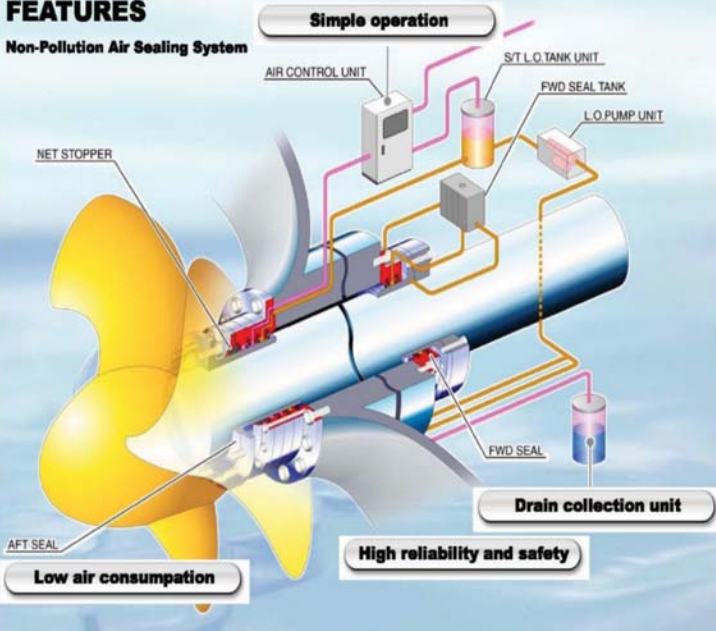

KEMEL

AX (Pollution Free) Seal

Visit www.kemelusa.com for more information on our Class Approved Pollution Free seal. AX seal system is pressure balancing for longer liner & seal life plus improved reliability.



For total EPA Compliance combine the AX system with our ST-77 Environmentally Preferable Patented Lubricant.

KEMEL USA INC

366 Fifth Ave, Suite 712
New York, NY 10001 USA
TEL: +1 212 967 5575
EMAIL: Hawkins@kemelusa.com
WEB: www.kemelusa.com

MARINE SEALING TECHNOLOGIES



To make it safely to harbor,
it takes a strong and agile partner.

Strength. Agility. Expertise. That's what counts in this business.

Ask for Great American coverage for:

Marine Commercial Liability • Ocean Cargo • Hull/P&I
Vessel Pollution • Terminal Operators • Vessel General Permit

GREAT AMERICAN
INSURANCE GROUP
Ocean Marine Division

www.GreatAmericanOcean.com | Contact Captain Ed Wilmot at 212-510-0135 | ewilmot@gaic.com

580 Walnut Street | Cincinnati, OH 45202

Marine Casualty Response

Preparedness & Leadership

By Jim Shirley



The operational, commercial, and regulatory complexities of marine casualty response have increased enormously over the last half century. In days past it was not unusual for the only responders to a vessel grounding in U.S. coastal waters to be the vessel owner's port captain or superintendent engineer, the insurer's surveyor, and the salvors. If significant amounts of oil were spilled, beach cleanup crews may have been manned by trustees mobilized from a nearby prison or some similar source of manpower. If the U.S. Coast Guard appeared on scene, it would have been for the purpose of protecting life and property, but they may also have monitored the pollution response. Contrast that with today's requirements, many of which have been driven by environmental and other public welfare concerns. Needless to say, there are so many responders today that efficiency and success require them all to work closely together as a team despite some having opposing or conflicting interests.

In the March issue of *MarineNews*, this column addressed the importance of informed marine casualty response. In large measure, each responder being fully informed of its own roles and responsibilities and reasonably knowledgeable of the roles and responsibilities of others is an important part of response preparedness. That article also addressed some of the initiatives of the American Salvage Association (ASA) and others designed in part to meet the objective of informed response. However, full preparedness requires more. As mentioned in the March article, the National Preparedness for Response Program (PREP) drills contribute to informed response. However, as the title of the program suggests, they are specifically designed to contribute much more to preparedness.

The regulations establishing the PREP Drill program were a subset of the regulations promulgated for Vessel and Facility Response Plans, a considerable and evolving

program. Captain Dennis L. Bryant USCG (ret.) is well known to thousands in the international maritime industry who receive his daily blog containing brief descriptions and comments on important maritime events, happenings, court decisions, and governmental actions. He is also well known to many for his frequent authoritative contributions in *Maritime Reporter & Engineering News*, a sister publication to *MarineNews*. Those who know Captain Bryant are not surprised to learn that he spent the last three years of his 27-year-long U.S. Coast Guard career as a leader on the Oil Pollution Act of 1990 (OPA 90) staff charged with writing the regulations. His final year was spent in charge of that entire group. Captain Bryant and his staff tackled many rule-making projects, of which, for the purposes of addressing U.S. Coast Guard leadership in the marine casualty response area, the PREP Drill program was of immense importance.

The success of this program speaks well for the benefit of the U.S. Coast Guard's leadership in safety and environmental protection. However, that success may not have been altogether apparent from the conduct of some of the early drills, all within what was then also the relatively new (to the marine response industry) Incident Command System (ICS). The ICS was sometimes particularly irksome to salvors in drill situations because, to serve the primary purpose of the drill of chasing, corralling, diverting, and recovering spilled oil, the drill had to sometimes ignore the possibility (or, in many cases, the probability) that the salvor might succeed in keeping the oil, or most of it, from spilling in the first place. In these drills, salvors were not always allowed the primary role they would likely play in an actual casualty situation.

Nonetheless, the PREP drills help train all the stakeholders in working together. They come into the drill incident filling their roles, with at least some understanding of the roles of other responders and stakeholders, and they practice working together to accomplish the ultimate objectives of the drill as if it were an actual event. This is something that cannot be learned in classrooms. Clearly,



EFFICIENT SEA

What difference does 24/7 onboard connectivity make? At Inmarsat, we believe it can help maximise your operational efficiency. When voyages take you beyond land-based network coverage, uninterrupted access to voice and data communications allows you to stay in touch with clients, share information with HQ, and contact port prior to arrival. Watch the film or talk to your service provider today to see what FleetBroadband can do for you.

FleetBroadband

With terminal options for every size and type of vessel, FleetBroadband delivers cost-effective, always-available voice, email, internet and SMS on all the world's oceans.

inmarsat.com/efficiency

preparation through broad-based drilling is better than preparation only through actual casualty response, which one would hope would be infrequent. It is also better than drilling that is narrowly focused to test only a few of the responders that are likely to participate in an actual event. Also, drilling can be kept current for all participants, whereas practice achieved only through actual response will likely be sporadic, and — in the best of circumstances, which history shows cannot be relied upon to last — can be non-existent for many designated response personnel for long periods. Each situation will always be different from any preceding it, and no amount of drilling is likely to make everyone familiar with every circumstance and every personality type that will be faced in every actual event. However, the more drill scenarios that are tested, the greater the familiarity that will be developed in the process of dealing with more of the differences. That is one reason why PREP drills today may accomplish as much, or more, in less time than was required for many of the PREP drills in the early years of the program.

As Captain Bryant advises, the regulations that established the PREP Drill program were a subset of the regulations promulgating the Vessel and Facility Response

Plans. Recent changes to oil tanker Vessel Response Plan (VRP) requirements, by adding the Salvage and Marine Firefighting regulations, found at 33 CFR Part 155, Subpart I, have moved preparedness for those vessels and the salvors listed in their VRPs to another level. In fact, these new regulations by their very terms may be expected to take preparedness to an altogether new level. The requirements they place on vessel owners and operators in the selection of their listed salvor(s) should eliminate those cases in which unqualified persons or entities were listed to fill that role. This article is not meant to address these new regulations in detail, however it is worth pointing out that the U.S. Coast Guard is still taking a leadership role, consistent with its oversight responsibilities, in ensuring that the public welfare, particularly in respect of the marine environment, will be protected well into the future as was the intention of Congress in passing OPA 90. Current and future PREP drills incorporating the new regulations may be expected to ingrain them into the system of response, ensuring that preparedness of all drill participants will begin at an earlier stage and be more complete than ever before. This has to be good for everyone.

The ABCs of MSAs

Reviewing your agreement may save you time and money

By Lawrence R. DeMarcay, III



Our industry is unique in that the operation of a vessel, offshore installation or a shipyard requires the hiring of numerous specialists that are needed on an on again/off again basis, often at a moment's notice. Under these conditions, there is almost never an adequate

amount of time to locate a vendor, negotiate terms, make the logistical arrangements and get the work done. Thus, companies often enter into Master Service Agreements (MSAs) with contractors that they may have a need to use.

MSAs are contracts between parties that are entered into in advance of the companies doing business together. Although they come in many different forms, they include agreed upon terms that will govern future transaction. MSAs often cover a wide range of services that a company can provide and do not obligate the parties to do anything until services are requested that are covered by the agreement. They also remain in place after the services are provided and stand ready to govern the terms of the companies' next transaction if and when the need arises.

The MSA differs from a usual contract because they often do not include the identification of a specific good or service to be provided or the costs for providing the goods or services. Those terms are often agreed to at the time that the services are requested. These terms are often controlled by pricing formulas, market pricing, terms agreed to when the order is placed or some other method that the parties agree on.

Often, in our industry, a company will have many MSAs in place at any given time. A small company may have a handful of MSAs in place where a large company may have thousands. There is also significant variety in the attention to detail each MSA provides. Most MSAs were originally written by an attorney that is familiar with drafting this type of agreement. However, over time, the "form document" is modified to suit the needs of the

company or the companies that it does business with. So many "form" agreements have had pertinent sections removed or have adopted language that is inconsistent with other sections of the agreement. As such, it is important to have someone within the company who is responsible for reviewing all MSAs to determine if they are adequate to control the activities of the parties in light of the type of business being transacted.

In the offshore environment, most MSAs include similar terms and conditions. These topics include a description of the services to be provided, a choice of law provision, indemnity requirements, defense requirements, insurance requirements, payment terms, the legal relationship of the parties, ownership of tools or equipment, management of the work, what documents include the terms of the agreement, notice requirements and regulatory requirements. The terms of a particular agreement can be general, or very specific, depending upon the nature of the operation.

Often, these agreements are entered into at the end of the sales process and the terms are negotiated by the sales people. In these situations, the sales people often agree to the waiver of, or addition of, terms that the company should not allow in their pursuit of the deal. When sales people are in charge of putting together the MSA, it may be a good idea to have another person review and approve the MSA before execution to make sure that the modified terms are still adequately protecting the company's interest.

Although it would be impossible to cover all potential terms in this article, most MSAs include similar language. For example, most MSAs, in the offshore setting, include a "knock for knock" indemnity agreement that provides that each party is responsible for indemnifying the other party for injuries to its employees. This indemnity obligation is also usually accompanied with a similarly worded insurance requirement that mandates that each party purchase insurance that provides coverage for the indemnity

obligation.

Although the concept seems simple, in practice it can be complicated. As MSAs are drafted to be used in a variety of settings, it is often difficult to specifically identify the parties to be indemnified. As such, we have seen agreements use terms such as “subsidiaries,” “related companies,” “members of the company group,” or companies “working for or with company.” Although these terms appear innocuous, once you request defense and indemnity from an injured worker’s employer, they may claim that they had no idea that you were within the scope of companies covered by the obligation. With that in mind, it is important to clearly identify the parties to be indemnified and to use language that is clear, easy to understand and can’t be described as being vague or ambiguous.

Another area to be wary of is the choice of law provisions. If it is a maritime contract, it is usually safe to agree to a provision that states that maritime law applies. If maritime law does not apply, it is also customary to have the law of the state in which the companies resides or where the work is being done as a secondary source. If a company suggests that another jurisdiction’s law should apply, look at the issue very carefully.

If the other side is insisting on it and you don’t know why, contact someone who knows before signing, as it probably does not inure to your benefit. An example would be a contract for the provision of necessities to a vessel that specifies that English Law applies. Although most people would assume English law is similar to general maritime law, it may not provide for a general maritime lien

against the vessel. Thus, if you provide necessities and are not paid, you would have inadvertently waived any right that you have to arrest the vessel to recover under the contract. But, during the sales process when every-

one was getting along, English law would not seem like a terribly offensive request.

In our practice we also like to include a provision that states that the executed MSA’s provisions control

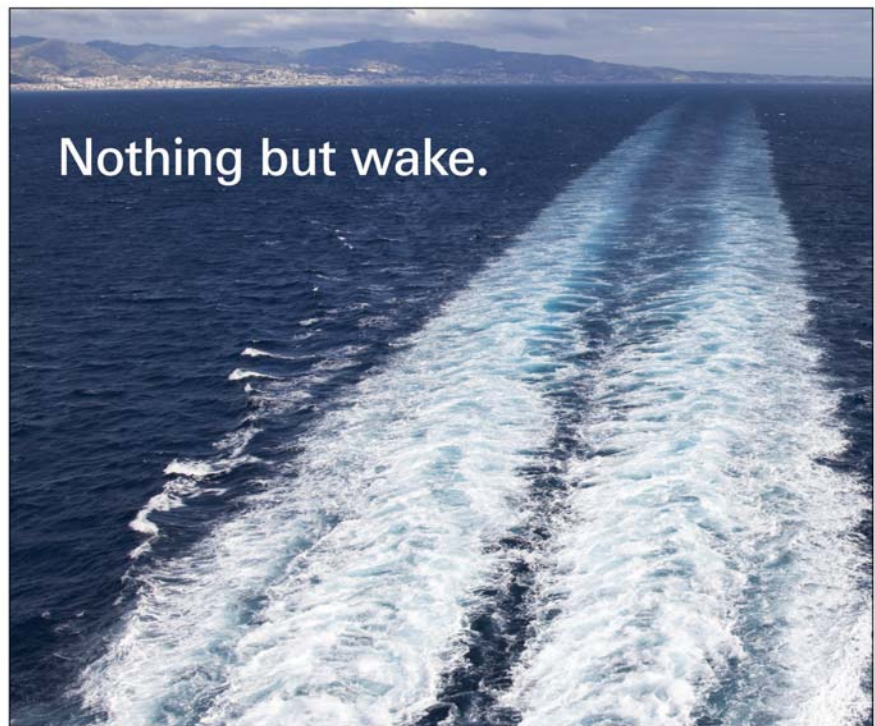

ZF Parts and Service — the intelligent choice.

Has poor service response time or inferior product parts set you adrift?

You want your vessel off and running through the water – not just sitting there “working on the downtime”. Genuine ZF Marine products are manufactured by our expert technicians to exact factory specifications, utilizing only genuine parts and exclusive testing technology. ZF Marine Parts and Service believes in the value of comprehensive customer support when providing complete propulsion technologies and components. A quality product, a seamless installation, and a satisfied customer – these are the results you get from our Genuine ZF network. ZF Marine is the only choice for getting you back out on the water as soon as possible.

**For all types of vessels. In every type of water.
There’s ZF Marine Parts and Service.**

www.zfmarineparts.com/amn

877.896.4040

Marine Propulsion Systems



AHEAD TANK™

**New IMO and USCG Certified
Type II Sewage Treatment Plant**



- Compact
- Lightweight
- Corrosion Resistant
- Odor Free
- Simple Installation
- Easy Maintenance
- Customer Friendly
- Cost Effective



Office: 337-237-5011

Email: headflusher@aheadtank.com

Web: www.aheadtank.com

the conduct of the parties and any previously exchanged offers, emails, or other documents are not to be considered as terms of the agreement. In the negotiation process, the parties usually exchange several rounds of offers and counteroffers while ironing out the terms of the agreement. Once the agreement is signed, all of these previous agreements should be cancelled as if they never occurred. Often, if a dispute about the terms of the MSA arises, someone will produce a document that indicated that the term should not have been included, or otherwise modified prior to execution. However, if you include a proper provision, the parties will be deemed to be aware of the terms of the document they signed and the parties must govern themselves accordingly.

Another area that we often recommend adding language relates to an award of attorneys' fees that incurred while requesting defense and indemnity. The general maritime law allows for the reimbursement of the attorneys' fees expended in defending the claim filed by an injured worker, if the MSA included an obligation to defend. However, the gen-

eral maritime law does not allow for the recovery of the attorneys' fees expended in pursuing the defense and indemnity claim. Thus, unless you have a specific provision that covers this area, the party that you request defense and indemnity from does not have any real incentive to quickly evaluate your tender. Adding language providing for the reimbursement of these fees increases the likelihood of recovering all of your fees and has the added benefit of putting pressure on the other side to fairly evaluate your tender.

Considering the importance of entering into an agreement that adequately portrays the company's intentions, as well as protecting each company's interest in the event of a dispute, great care should be put into ensuring that MSAs are entered into when appropriate and that each agreement includes the terms necessary for the successful management of the service to be provided. A little time spent coordinating the execution of MSAs and reviewing existing MSAs to make sure they are adequate can save you a lot of time and expense in the event that a dispute arises. For example, the specific language used in an indemnity agreement could be enforceable or not enforceable under the general maritime law, or different state laws. So, it is a good idea to have someone knowledgeable about the terms of MSAs review these documents, on an ongoing basis, with an eye towards what is customary, reasonable and enforceable. Allocating resources to this task may save you significant time and money by avoiding a future dispute.

NABRICO

1250 Gateway Drive • Gallatin, TN 37066

**WE OFFER A COMPLETE LINE
OF DECK FITTINGS.
CATALOG AVAILABLE.**

615-442-1300
FAX: 615-442-1313
www.nabrico-marine.com

...OUTFITS THEM ALL

Do you know your **Bowditch** from your **Bottom Line**?

By Richard J. Paine, Sr.



Short of an MBA in finance, every mariner, captain, operations manager or owner of a commercial vessel should understand

the workings of the financial side of our industry. It's no longer enough to know port from starboard or if you've made or lost money. You now have to understand such arcane topics as derivatives, hedges, depreciation, amortization, rates of return on investment and equities, ratios and ratings, among other issues. You need to understand how they affect your employment and the health of your business just to survive.

Happily, just as you were not alone in mastering Bowditch and bowlines, there are resources available to you to bring you up to speed in the art and science of commercial marine-finance and help you to prosper in our new economy.

For the basics of accounting and finance, your first and best resource may be your local state maritime academy. Where better to turn then to the institutions whose focus is on our industry. This following list is not meant to be complete and courses change from semester to semester. As a caveat, certain courses may be available as standalone while others may require prerequisite courses. Your best bet is to contact the school's admissions office and discuss their offerings, costs and policies. That said, here is a sampling of what our Academies currently offer:

- California Maritime Academy
<http://www.csum.edu>

ABS School of Maritime Policy and Management offers Business 100 –

Take YOUR Diesel Engine to the Next Level with Walker AIRSEP®

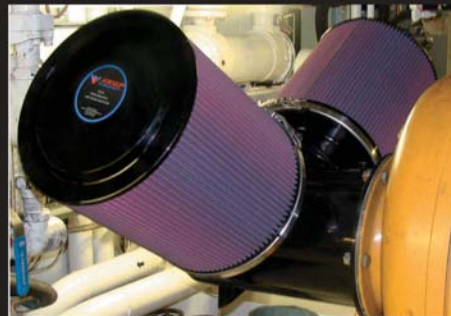

Now Available for CAT® 3600 & C280 Engines

- High-Performance Air Filter Silencers.
- Walker AIRSEP CCV SYSTEMS.
- All Rated for Commercial Duty.

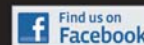

www.facebook.com/Walkerairseps

Call for more information, or send an e-mail for a quotation.
Ask about Special Freight Allowances. Fleet upgrades welcome.

Walker Engineering, USA. 818.252.7788, sales@walkerairseps.com

CAT® and Caterpillar® are registered trademarks of Caterpillar Inc.

Accounting Principles, Financial; Business 101 – Accounting Principles, Management; and Business 310 – Financial Management. The link to their course catalog is: <http://csum.edu/web/faculty-and-staff/academic-catalog>

- **Maine Maritime Academy**
<http://mainemaritime.edu>

Offers Ma-211 – Financial Accounting; Ma-242 – Managerial Accounting; and Ma-303 Financial Management. The link to their course catalog is: <http://dean.mma.edu.newcatalog/default/htm>

- **Massachusetts Maritime Academy**
<http://maritime.edu>

Offers IM-2121 – Accounting I; IM-2221 – Accounting II; IM-3133 – Finance I ; IM-3233 – Finance II; and FM-2020 – Financial Analysis for Facilities Managers. The link to their course catalog is: <http://www.maritime.edu/uploads/files/mmcatalog.pdf>

- **Great Lakes Maritime Academy, Northwestern Michigan College**
<http://nmc.edu/maritime>

Offers ACC 121 – Accounting Principles I; ACC 122 – Accounting Principles II; ACC 221 – Intermediate Accounting I; ACC 222 – Intermediate Accounting II; ACC 225 - Cost/Management Accounting and after you've met all the requisites

and find that you like GAAP more than STCW, you can apply for an accounting internship in ACC 290. The link to their course catalog is: <http://www.nmc.edu.programs/catalog-schedules/pdf>

- **Texas Maritime Academy, Texas A & M University at Galveston**
www.tamug.edu

Offers ACCT 229 and 230 – Introduction to Accounting; FINC 341 – Business Finance; ACCT 315 and 316 – Intermediate Accounting for Non-Accounting Majors; FINC 341 – Business Finance; MARA 342 – Managerial Maritime Finance; MARA 424 – Economics of Transportation; ECON 311 – Money and Banking. The link to their course catalog is: <http://tamug.edu/catalog/CAT133PDF's/CAT133.pdf>

- **Maritime College State University of New York, Ft. Schuyler**
www.sunymaritime.edu

Offers GBAC 311 – Financial Accounting; GBAC 315 Managerial Accounting; GBEC 323 – Banking and Financial Markets; GBEC 427 Financial Management; TMGT 8210 – Transportation Managerial Accounting; TMGT 8220 – Financial Decision Making in Transportation; and TMGT 8230 – Ship Finance. The link to their course catalog is: http://www.sunymaritime.edu/documents/2010/6/2010DegreeCurricula07-01-2010_A.pdf

In researching this column, I gained

a new appreciation for our young and upcoming mariners as well as our ancient classes of ring-knockers. While many of their contemporaries were pursuing psychology, poly-sci and other, shall we say less rigorous degrees, our professional mariners were following a curriculum that demanded intelligence, perseverance and a true dedication to the business and science of the sea.

Graduating with a degree from any of the aforementioned schools is an accomplishment to be proud of.

For the rest of us who just need a little financial education, the resources are no less varied. Uncle Sam offers a “Beginners Guide to Financial Statements.”

It will school you in the basics so that if you own or work for a company, and want to judge it's financial strength and your probability for continued employment, read and understand it. As its introductory paragraph says it will “not train you to be an accountant, but should give you the confidence to read financial statements and make sense of them.” Go to <http://sec.gov/investor/pubs/begfin-stmtguide.htm>

Stanford University also offers a nice little booklet to get you started at <http://stanford.edu/class/msande271/onlinetools/howtoreadfinancial.pdf>

And of course, you can always call a marine-finance consultant for a one-on-one training session or two to help you better understand some of those more arcane/esoteric areas of finance.

MTU for Sause Bros. Fleet Modernization

Starting with a single small wooden tug in the 1930s, Sause Bros. has grown its fleet to 60 tugs and barges. Sause Bros. barges petroleum, lumber, plywood, paper and chemicals between many Pacific Ocean ports in the United States, Central and South America, the South Pacific and even Russia.

Typical one-way trips can range from 1,200 to 2,400 nm, and some are much longer. In addition, the company's vessels are hired for ocean-towing and ship-assist jobs. One key to the company's continued success has been a long-term fleet modernization program which included a decision to replace its existing medium-speed marine diesel engines with high-speed marine diesels from MTU.

Today, a little over one-third of the tugs and barges in the Sause Bros. fleet are powered by MTU Series 4000 and Series 2000 Ironmen marine diesel engines. The tugs feature MTU Series 4000 engines with 12V and 16V cylinder configurations, as well as 12V Series 2000 and Series 60 engines. The most powerful of these engines, the 12V and 16V Series 4000 units, are installed in the company's long-distance ocean-towing tugs, while Series 2000 and Series 60 engines power tugs that operate in harbors. All of the company's MTU equipped barges are powered by Series 60 engines.

Because of the modernization program, Sause Bros. has been able to achieve a 30 to 47% reduction in fuel consumption. The company estimates that up to 15% of the savings can be attributed directly to the new fuel-efficient MTU engines. MTU engines also offer lower lube-oil consumption and lower exhaust emis-

sions. Series 4000, 2000 and 60 engines all meet EPA Tier II emissions standards, a requirement for boats operating in California waters. So far in its modernization program, Sause Bros. has equipped more than 10 tugs with MTU engines.



Photo: MTU

LARGEST RENTAL FLEET OF SPUD, DECK AND MATERIAL BARGES



BARGES 60' TO 400' LENGTH

- 16 Fleeting locations inland rivers, Gulf, East and West Coast
- Inland and Ocean towing services



McDonough Marine Service

SINCE 1945

New Orleans

(504) 780-8100 • Fax (504) 780-8200

Norfolk

(757) 545-0100 • Fax (757) 545-8004

Houston

(281) 452-5887 • Fax (281) 452-9682

www.mcdonoughmarine.com

Charting the Future

In the Annual Leadership Edition of *MarineNews* we bring you a line up of executives with insights on market conditions, legislation and business strategies for the coastal and inland waterways and salvage fields; an insiders view on trends that will define the workboat market for years to come.



What is your outlook for the market you serve in 2011/2012 and beyond?

CHARLES JONES, CHAIRMAN OF THE BOARD, AMHERSTMADISON All our line boats are chartered to companies that own dry cargo barges and they are predominately in the coal trade. Despite adverse publicity we will continue to use substantial quantities of coal to produce electricity and for at least the next five years we look for a substantial export market of coal, both thermal and metallurgical, from the Gulf ports. In addition, we feel the aggregate trade will maintain itself for the same period because highway maintenance alone is so far behind schedule. We also feel that petroleum products and chemicals will maintain themselves.

JOHN ECKSTEIN, CHAIRMAN, PRESIDENT & CEO, MARQUETTE MARINE TRANSPORTATION After our next new builds are delivered we will have over 800 barges, but our primary business is as a boat operator. I was excited about the prospects for a strong 2011 and even stronger 2012. U.S. farmers were planting a large crop and export demand was looking strong. This combined with a large coal export program and improving northbound and liquid demand pointed to high demand for horsepower. However, the current flooding is not only hurting current operations but could have lingering negative effects on

demand as crop conditions deteriorate. I do feel that demand for horsepower will continue to be strong as the stress on the system will continue to negatively impact logistics. All in all, I am still bullish long term, especially for horsepower.

JOHN ARNOLD WITTE, JR., EXECUTIVE VICE PRESIDENT, DONJON As a result of Donjon's business philosophy, "diversity of service," we are always hopeful when looking to the future. While Donjon's first area of concentration was exclusively marine salvage and related services, over the last 45 plus years Donjon has diversified into the areas of heavy lift, marine transportation, dredging, construction and support and, most recently, shipbuilding and repair through our acquisition of Donjon Shipbuilding and Repair located on Lake Erie in Erie, Penn. While one area of service may be slow, one or all of the other areas are likely not. As far as our outlook for 2011/2012, we see a positive upswing in the marine industry as a whole. This is evidenced by the recent increase in our heavy lift stevedoring, dredging, vessel and metals recycling and marine transportation services. Marine salvage, while a core Donjon business, is on the decline due to increased liabilities to vessel owner/operators as a result of legislation like the Oil Pollution Act of 1990. But, as long as vessels con-

tinue to transit the oceans, rivers and bays of our marine environment, marine salvage and related services will be needed.

JAMES STARK, EXECUTIVE DIRECTOR, GICA GICA works closely with its members and federal and state stakeholders on waterways matters, focused on keeping commerce moving throughout the five-state GIWW area. Although trend data for cargoes transported by the barge industry is still catching up to pre-recessional levels, I believe our industry remains solid. The GIWW plays a major role, behind only the Mississippi River and the Ohio River in terms of tonnage moved on the inland waterways — over 108 million tons annually. Clearly, shippers on inland waterways are always looking at efficiencies and costs as they move their commodities to production plants and products to market. The GIWW offers shippers an advantage in gaining those efficiencies. As fuel costs rise and over the road transportation becomes increasingly congested, barge transportation becomes more attractive and GICA member companies have the capacity and expertise meet customers' GIWW needs.

How is your company investing for the future?

JOHN ARNOLD WITTE, JR., EXECUTIVE VICE PRESIDENT, DONJON Donjon continues to reinvest in the equipment and personnel required to support our core businesses. We promote from within and use both the experience of our long-term employees plus appropriate outside training to keep the employee pipeline full. We have recently

www.marinelink.com



IsatPhone Pro



Inmarsat's first global handheld satellite phone with bluetooth technology.

Fleet Broadband



Cost effective broadband connectivity providing voice & data simultaneously through the Inmarsat network.

MCG-101



Bring your entire office onto the Boat with our Iridium PBX!

YOUR ONE-STOP GLOBAL SATELLITE PROVIDER



Tel: +1 954 522 6260

Email: marinenews@globalsatellite.us

Website: www.globalsatellite.us

**Head Office in Fort Lauderdale, Florida
Regional Offices in Europe & Africa**



LOOKING FOR A SHIP, DREDGE, OR BARGE BUILDER?

LOOK NO FURTHER!

Steelways, Inc. is located on the Hudson River only 50 miles from NYC. Utilizing a shipyard with 60 waterfront acres, and 3 sheltered harbors, Steelways, Inc. is the choice for Vessel, Ship, Dredge & Barge Construction.

**Let's get it started.
(845) 562 0860**

401 S. WATER STREET • NEWBURGH • NY 12553
www.steelwaysinc.com info@steelwaysinc.com



STEELWAYS

Leadership Edition



**Chairman of the Board,
AmherstMadison**

Charles Jones

“The river transportation industry is currently suffering from over regulation and in addition we are faced with the imposition of what is known as Sub-Chapter M certainly by the end of 2012. This, plus the emissions standards of the EPA which are currently in place and will be imposed on the grandfathered main propulsion engines in towboats will have a significant impact on our business. The brown water transportation industry in most cases is not profitable enough to do the hull work and purchase new engines to comply with these new standards.”

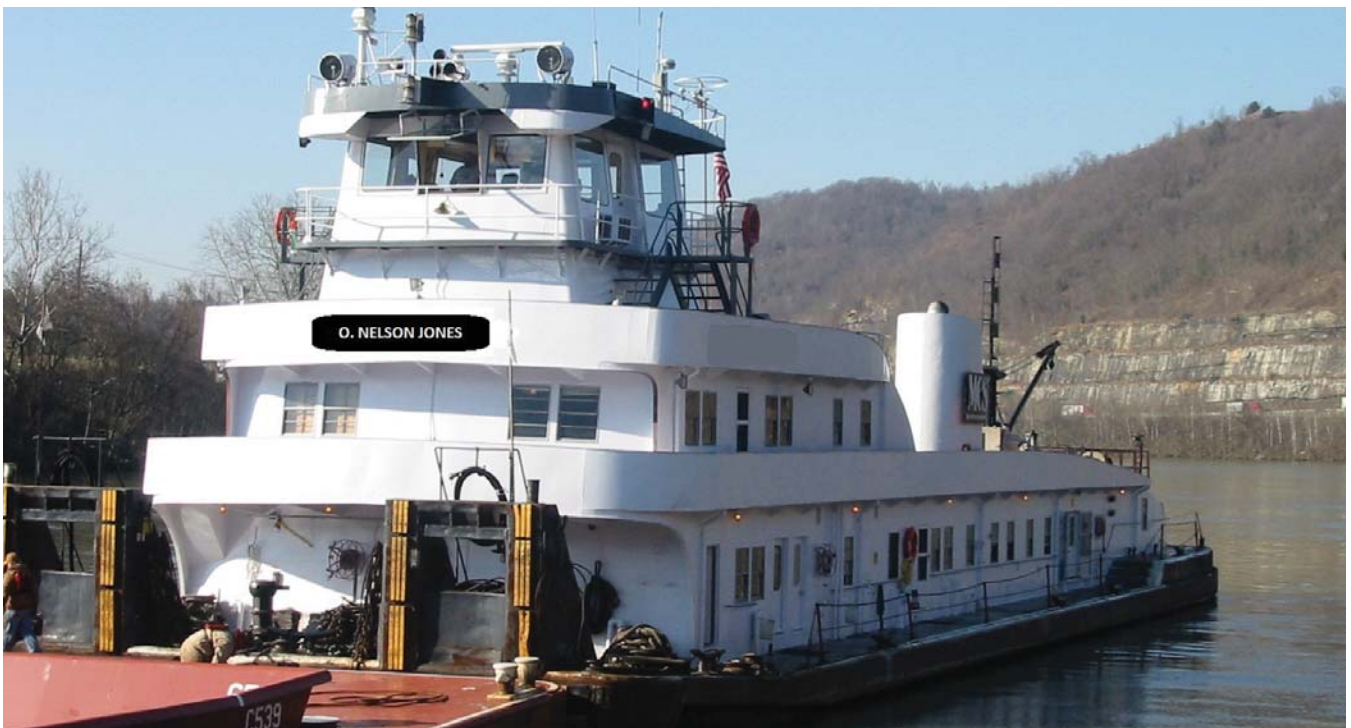

Photo courtesy Port of AmherstMadison

AmherstMadison's MV O. Nelson Jones

added a significant number of marine transportation related equipment which supports all aspects of our maritime activities. We also have begun construction of a new 4,000 cubic yard dump scow to increase our dredging capability at our recently acquired shipbuilding and repair facility. We added a 34,000-ton capacity self unloading articulated tug/barge unit to the fleet, scheduled to be ready for service in support of Great Lakes bulk transportation needs for the 2012 season. We are 50/50 partners in this vessel with Seacor Maritime.

JAMES STARK, EXECUTIVE DIRECTOR, GICA GICA members are investing in new boats and barges. This was especially true in 2010 when a dip in steel prices and tax incentives made recapitalization appealing. On the Gulf coast, towing companies have been regularly christening and placing new vessels into service. Additionally GICA members are working closely with USACE, USCG and NOAA as part of a Gulf Coast Inland Waterways Joint Hurricane Team to ensure waterways are opened as soon as possible after a storm's passing.

CHARLES JONES, CHAIRMAN OF THE BOARD, AMHERSTMADISON Our company is continuing to bring in younger personnel to maintain an effective organization for the future. We have been and continue to purchase newer, larger cranes and other related equipment for our construction business. In addition, we have purchased a number of new deck barges for our construction division which, in some cases, is a flight from poorly earning securities into fixed assets.

JOHN ECKSTEIN, CHAIRMAN, PRESIDENT & CEO, MARQUETTE MARINE TRANSPORTATION We just finished construction of 50 new barges and are building another 69 through the first quarter 2012. We took delivery of two new 2,000 hp vessels in the gulf and put into service our largest vessel to date, the 9000 hp Loree Eckstein. We also recently added a vessel to our offshore division. Along with that, our steersman program will go from near zero participants five years ago to 25 by year end. This increased investment in pilots for the future is a necessity if we want to continue to operate at the high level of quality that has been paramount to our success.

GLOBAL MARINE POWER, LLC
MARINE ENGINES • POWERPLANTS • TURBOCHARGERS
 GLOBAL MARINE POWER, LLC • 6720 C MAYFAIR ST, HOUSTON, TX 77087 USA
 +1 (713) 640-9300 (TEL) • +1 (713) 640-9302 (FAX)
 WWW.GLOBALMARINEPOWER.COM

Global Marine Power, LLC carries quality equipment at competitive prices. We assure you of our business services without compromising on quality and time. Global Marine Power, LLC undertakes complete repair and annual maintenance contracts. We also provide consulting services to power plants.

**MARINE ENGINES – 2 & 4 STROKE
 – MAIN & AUXILIARY ENGINES & SPARES
 POWER PLANTS
 GENERATORS
 SEPARATORS
 COMPRESSORS & REFRIGERATION
 ANCHORS & ANCHOR CHAINS**

“We specialize in Bergen - Normo and Wärtsilä Engines/Spares”

Leadership Edition



**Chairman, President & CEO,
Marquette Marine Transportation**

John Eckstein

“We just finished construction of 50 new barges and are building another 69 through the first quarter 2012. We took delivery of two new 2,000 hp vessels in the gulf and put into service our largest vessel to date, the 9000 hp Loree Eckstein.”



Photos courtesy Marquette Transportation

Marquette Marine's MV Kay A Eckstein.

What recent or pending legislation will have the most significant impact on your business?

RICK CALHOUN, CHAIRMAN, WATERWAYS COUNCIL, INC.

As Chairman of Waterways Council, Inc., the number one legislative priority is to see the Inland Waterways Capital Development Plan (CDP) move forward as part of a Water Resources Development Act (WRDA). The CDP is a consensus-based plan that was developed over an 18-month period by the Inland Waterways Users Board, on which I serve, and by the U.S. Army Corps of Engineers to prioritize navigation projects on the inland system and define a way to efficiently fund them over the next two decades. This new plan would require the industry to increase the tax it currently pays into the Inland Waterways Trust Fund by 35 to 45%. While never an easy decision to raise taxes in an uncertain fiscal environment, the industry supports this as a way to fix the current broken, inefficient model for constructing navigation projects. If passed, the legislation will allow 25 projects to be built over 20 years versus just six over the same period under the current system.

JOHN ARNOLD WITTE, JR., EXECUTIVE VICE PRESIDENT, DONJON

New and changing regulations by the federal, state and local governments cover such wide ranging issues as crew training, equipment maintenance, vessel inspections and office support/record keeping to name a few. In my view, the most important legislation recently passed is the final implementation of the Oil Pollution Act of 1990. As a result of the Exxon Valdez casualty in 1989, the federal government enacted OPA-90 to ensure that there are

sufficient response assets to deal with any maritime casualty. With the protection of our environment a top priority, the final implementation of OPA-90 provides support, not subsidy, to the true professional U.S. marine salvage community. Among numerous emergency response requirements, OPA-90 requires that owners/operators of all tank vessels that transit U.S. waters have an agreement in place with a professional and experienced salvor in the event of a casualty. OPA-90 does not require that vessel owners/operators subsidize the marine salvage community, only that they must contract with a professional salvor in the event of a casualty rather than a "yellow pages" salvor who chooses to try to respond without the experience, equipment and personnel necessary to mitigate the problem. OPA-90 has provided the support necessary to allow professionally trained marine salvors to continue to be financially viable today and into the future.

CHARLES JONES, CHAIRMAN OF THE BOARD, AMHERSTMADISON

The river transportation industry is currently suffering from over regulation and in addition we are faced with the imposition of what is known as Sub-Chapter M certainly by the end of 2012. This, plus the emissions standards of the EPA which are currently in place and will be imposed on the grandfathered main propulsion engines in towboats will have a significant impact on our business. The brown water transportation industry in most cases is not profitable enough to do the hull work and purchase new engines to comply with these new standards.



A hard hat, a flashlight and sound,
professional judgement will always form
the bedrock of effective classification services.

Setting the Standard for Service.



Leadership Edition



Executive Vice President, DonJon

John Arnold Witte, Jr.

“Donjon continues to reinvest in the equipment and personnel required to support our core businesses. We promote from within and use both the experience of our long-term employees plus appropriate outside training to keep the employee pipeline full. We have recently added a significant number of marine transportation related equipment which supports all aspects of our maritime activities.”



Photos courtesy DonJon

DonJon dredging operations

30 MN

June 2011

What do you consider to be the biggest challenge to running a profitable inland waterways business today?

**JOHN ECKSTEIN, CHAIRMAN, PRESIDENT & CEO,
MARQUETTE MARINE TRANSPORTATION**

There are many challenges facing inland operators today and it's hard for me to pick just one, so I will give you two: quality pilots and infrastructure. During my first 10 years at Marquette, we never had a problem crewing vessels, even in the wheelhouse. This caused the industry, including Marquette, to not create enough new pilots because it is very expensive to do so. Now, with some growth in the last decade combined with an aging pilot workforce, all companies have found it difficult to find enough quality wheelmen. As a result, we have expanded our steersman program, as I previously mentioned. Infrastructure is a no brainer. Most of the infrastructure on the inland waterway system has far outlived its useful life. Unless we spend some needed capital on it, this country will lose a valuable resource that helps keep us competitive in the world markets. Other countries are spending billions of dollars and can only dream of having a system such as ours. It's up to all of us to convince our elected officials of this point.

JAMES STARK, EXECUTIVE DIRECTOR, GICA GICA works closely with its members and federal and state stakeholders on waterways matters, focused on keeping commerce moving throughout the five-state GIWW area. Although trend data for cargoes transported by the barge industry is still catching up to pre-recessional levels, I believe our industry remains solid. The GIWW plays a major role, behind only the Mississippi River and the Ohio River in terms of tonnage moved on the inland waterways — over 108 million tons annually. Clearly, shippers on inland waterways are always looking at efficiencies and costs as they move their commodities to production plants and products to market. The GIWW offers shippers an advantage in gaining those efficiencies. As fuel costs rise and over the road transportation becomes increasingly congested, barge transportation becomes more attractive and GICA member companies have the capacity and expertise meet customers' GIWW needs.

The lack of a coherent infrastructure recapitalization plan for the inland waterways system remains the biggest challenge to running a profitable inland waterways business. If we can't count on dependable waterways struc-

tures, then delay costs rise and customers look elsewhere. What is troubling is that the fine work of the Inland Waterways Users Board (IWUB) and its consensus Inland Waterways Capital Development Plan has been rejected by the current Administration and Congress doesn't seem to have the appetite to take on the issue through a comprehensive WRDA solution. The plan proposed by the IWUB included a fair, carefully crafted cost sharing plan, objective criteria for prioritizing projects and substantive recommendations for streamlining USACE project delivery processes. In addition to this recapitalization challenge, significant shortfalls in USACE operations and maintenance funding make operations on the GIWW more difficult. As a result, GICA is adding its voice to the many others in the industry advocating better funding for this critical transportation system.



Chrome... more than just show!

CHROME
CRANKSHAFT COMPANY LLC

**LOCOMOTIVES
MARINE
DIESEL ENGINES
MACHINERY**

COMPLETE CRANKSHAFT RECONDITIONING
Providing quality service for over 50 years

- ABS CERTIFIED PROCESS FOR REPAIR OF EMD AND ALCO CRANKSHAFTS
- INSPECTION SERVICES
- SUBMERGED ARC WELDING
- CAPACITY 18' LONG 44" SWING 18" STROKE

4166 MOUND ROAD, JOLIET, ILLINOIS 60436
TEL: 815-725-9030 FAX: 815-725-9930
www.chromecrankshaft.com

Leadership Edition



Executive Director, GICA

James Stark

“GICA works closely with its members and federal and state stakeholders on waterways matters, focused on keeping commerce moving throughout the five-state GIWW area. Although trend data for cargoes transported by the barge industry is still catching up to pre-recessional levels, I believe our industry remains solid.”



Photo courtesy USACE

The Gulf Intracoastal Waterway enters Galveston Bay from Bolivar Peninsula.

**RICK CALHOUN, CHAIRMAN,
WATERWAYS COUNCIL, INC.**

As WCI Chairman, I would say the biggest ongoing challenge for our association is always to convince decision-makers in Congress about the critical importance of the nation's waterways and all that they provide to the nation in terms of exports, jobs, energy efficiency, traffic congestion relief and protection of the environment. We are a small industry compared to truck and rail, often out of sight, out of mind, yet just as important as we consider the intermodal world we operate in. The waterways provide the way forward for helping our nation to double its exports over the next two years, but we cannot accommodate that goal if our lock and dam infrastructure is at risk of catastrophic failure. The lock and dam system — just like other infrastructure in other modes — requires recapitalization and the Capital Development Plan will help our nation to maintain its competitive edge for getting our grain and other commodities to the world market more cheaply than other nations.

The Leaders

**RICK CALHOUN, CHAIRMAN,
WATERWAYS COUNCIL, INC.**

For the past two years Rick Calhoun has been Chairman of the Waterways Council, Inc., the national public policy organization which advocates for a modern and well-maintained national system of ports and inland waterways. Calhoun is Vice President of Cargill's North American Grain & Oilseed Business Unit in Minneapolis, Minn.

DONJON

STANDARDS. SOLUTIONS. SUCCESS.



Donjon Marine provides the most innovative solutions to your dredging, marine salvage, marine transportation, marine demolition, heavy lift, vessel recycling, site remediation, ocean engineering, towing and diving challenges.

Since 1964, Donjon has offered full-service marine solutions from the smallest to the most complex, here and around the globe, powered by the strength of our employees, our experience, and our equipment.

Let us offer our marine service solutions to your business.

At Donjon, marine service is our business.



DONJON MARINE CO., INC.
100 Central Avenue
Hillside, New Jersey USA 07205
tel. (908) 964-8812 www.donjon.com

DEFY CONVENTION



THE 38 DEFIANT FROM METAL SHARK:
A NEW BREED OF FORCE PROTECTION BOATS

RUGGED. DURABLE. DEFIANT.



WWW.METALSHARKBOATS.COM
SALES@METALSHARKBOATS.COM
(337) 364-0777

Leadership Edition

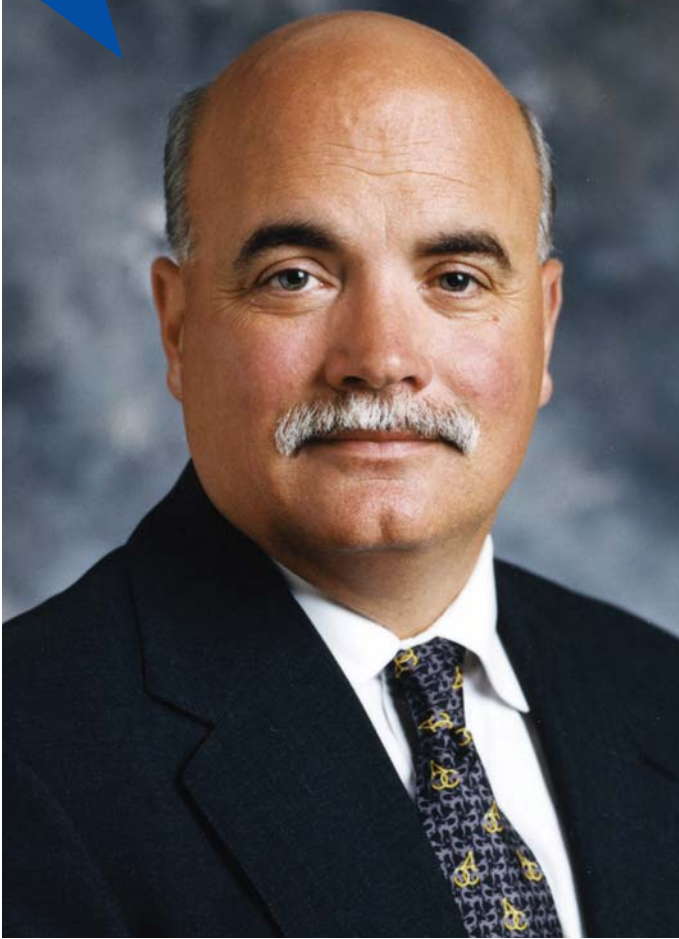

Chairman, Waterways Council, Inc.

Rick Calhoun

“As WCI Chairman, I would say the biggest ongoing challenge for our association is always to convince decision-makers in Congress about the critical importance of the nation's waterways and all that they provide to the nation in terms of exports, jobs, energy efficiency, traffic congestion relief and protection of the environment.”

**JOHN ECKSTEIN, CHAIRMAN,
PRESIDENT & CEO,
MARQUETTE MARINE TRANSPORTATION**

John P. Eckstein serves as Marquette Transportation Company Holdings, LLC's Chairman of the Board of Directors, President and CEO. He joined the company in 1990. Marquette Transportation operates 116 tow and tug boats and approximately 800 barges through three primary segments: river, gulf-inland and offshore.

**JOHN ARNOLD WITTE, JR.,
EXECUTIVE VICE PRESIDENT, DONJON**

John A. Witte, Jr. is Executive Vice President of Donjon Marine Co., Inc., provider of marine services including marine salvage, heavy lift, dredging and related emergency

response services since 1982. Witte also served as President of the American Salvage Association (ASA) from 2007-2009.

**CHARLES JONES, CHAIRMAN OF THE BOARD,
AMHERSTMADISON**

After serving in the Navy during World War II Charles Jones went back to work for a U.S. mining company that shipped coal by barges. From there he became part of the creation of a river transportation company that bought its first barge in 1948. AmherstMadison is a direct successor of a coal company Jones' grandfather started in 1893 in Red Star, W.Va. Today AmherstMadison operates 30 tow-boats, 11 floating cranes and 30 construction barges and related equipment.

JAMES STARK,
EXECUTIVE DIRECTOR, GICA

Before becoming the Executive Director for the Gulf Intracoastal Canal Association (GICA), James Stark served in the Coast Guard for 28 years and was the FEMA Assistant Administrator for Gulf Coast Recovery following Hurricanes Katrina and Rita. GICA is the trade association representing industry members involved in towboat and barge operations, shipping, shipyards and associated waterways industries which use the Gulf Intracoastal Waterway (GIWW) between Brownsville, Texas and St. Marks, Fla.

New York State Canal System

GREAT LAKES TO ATLANTIC

SHIP BY CANAL

518-471-5349 www.canals.ny.gov

Marine News ADVERTISE WITH US!
 ONLY MARINE NEWS DELIVERS THE ENTIRE SHALLOW DRAFT MARKET!

WORKBOAT

OFFSHORE

INLAND

COASTAL

www.marinelink.com

PosiTector® DPM
Dew Point Meter

NEW

Measures and records climate conditions during surface preparation and application of coatings as required by ISO 8502-4 and ASTM D3276.

- **Internal Memory** stores 2,500 datasets in 100 batches
- **Graph Mode** charts all 5 parameters onscreen
- **Smart Trend™ Indicators** identify rising or falling readings

Magnetic Surface Temperature probe available for hands-free recording

DeFelsko® 1-800-448-3835 or www.defelsko.com

Phone: 315-393-4450 • Email: techsale@defelsko.com • Ogdensburg, New York USA

MADE IN THE USA

Leadership Edition

Crowley

Carrying on a Family Tradition

Tom Crowley, Jr. is Chairman and CEO of Crowley Maritime Corporation. “I started officially with a paying job when I was 16, taking tickets for the passenger boats we had in San Francisco Bay,” he said, referring to the Red and White Fleet that was sold off in the late 90s. “I went to University of Washington in Seattle and worked for the company in summers. When I graduated I went to Jacksonville, Fla. and worked in the management training program, then came back to San Francisco to run the Red and White Fleet as the general manager. From there I took over local tug operations. Then my father passed away in 1994 and that’s when I took over as Chairman and CEO.”

Even before that, Tom Crowley, Jr. had an inside view of his father’s business. “My dad was older. He was 53 when I was born. The company was a really big part of his life. He wasn’t much into sports or throwing the ball on Saturday afternoon, so he would take me down to the shipyard and we would go drive a tug boat around or pick through the scrap heap to see what we could make something,” he said. “I always enjoyed it. He never pressured me to take on the job.”

With 17 years under his belt now as Chairman and CEO, Crowley said, “there’s a lot of great people here. I’ve got a tremendous amount of support from people who



The world’s most trusted maritime antenna system.

www.cobham.com/seatel www.facebook.com/seatel

have been around longer than I have. I think we've done a good job on building on our strong culture."

A strong company culture is one of the strengths he said has led to Crowley Maritime's success despite the challenges facing tug and barge operators. Unfortunately, those challenges make doing business in the U.S. more difficult, "which to me is surprising, given our economic state, you'd think we would be trying to be more competitive. But that has not occurred."

Too much capacity and not enough demand for vessels is one big challenge. "Since the downturn of economy there is more tonnage available than the market can bare. Puerto Rico, as an example, has tremendous fall-off in cargo volumes and yet the capacity remains constant. That has driven pricing down. The same could be said on the oil transportation side of the business. Gasoline demand in the U.S. has continued to drop. That has certainly put an oversupply on Jones Act tanker trade. Capacity doesn't seem to leave the Jones Act trade nearly as quickly as the international trades."

"The other challenge is the backwards direction we've taken on our energy policy in terms of drilling." Crowley



Images courtesy Crowley Maritime Corporation

In late 2010, two of Crowley's high-deck strength barges, 455-3 and Marty J, towed by tugs Warrior and Commander, transported processing and utility modules, and other smaller structural components more than 8,000 miles from Gulf Island Fabricators in Houma, La., to Point Oliktok in Kuparuk, Alaska. The modules and components, each weighing nearly 4,000 tons, will support Eni's development of the Nikaitchuq oil field.

Rough and Ready



+



+



=

Sea Tel
COBHAM

Leadership Edition



Images courtesy Crowley Maritime Corporation

The hull of Crowley's Ocean Class tug under construction at Bollinger Shipyards in Louisiana

referred to the Deepwater Horizon spill and the ensuing moratorium, saying “the slow down in that area has again created capacity issues. I think people were certainly building up to be able to service the offshore market and now that’s slowed down considerably.”

Besides the issues with drilling in the Gulf of Mexico, Crowley said, “drilling onshore within Alaska has slowed considerably, because of disagreements with the state.”

“That certainly impacts the barge trade up into Alaska where they aren’t taking cargoes up to the North Slope like they used to. The flip side is, if we did have a more proactive energy policy that was promoting this kind of stuff, those drilling projects would be happening and the coast-wise business would be benefiting from it.”

“We have three heavy lift barges that we just towed over to Asia that typically



H.O. Bostrom Co., Inc.

Shock Mitigating
Marine Seating
Systems for
Comfort and Safety

- Waukesha, WI USA
- Hamburg, Germany
- Shanghai, China

Made in the USA



www.hobostrom.com



Pacifica Pilot
with Floor Slide



JX-190 Jockey Seat



Pacifica with Torsion
580 Suspension

Tel: 262-542-0222

Fax: 262-542-3784

Email: sales@hobostrom.com

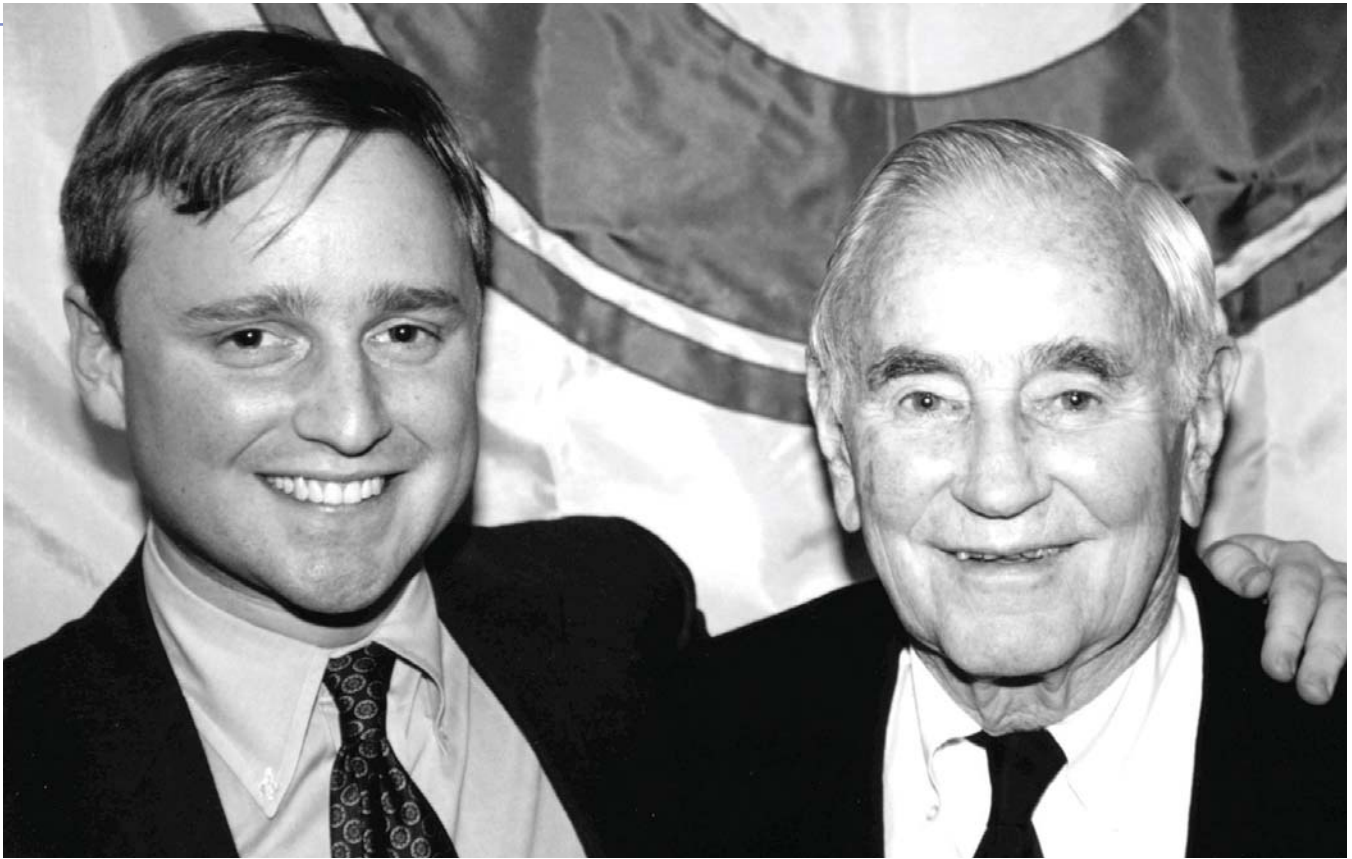

Images courtesy Crowley Maritime Corporation

Chairmen & CEO, Crowley Maritime Corp.

Tom Crowley, Jr.

“My dad was older. He was 53 when I was born. The company was a really big part of his life. He wasn’t much into sports or throwing the ball on Saturday afternoon, so he would take me down to the shipyard and we would go drive a tug boat around or pick through the scrap heap to see what we could make something,” he said. “I always enjoyed it. He never pressured me to take on the job.”

(Above, Tom Crowley Jr. with his father, Tom Crowley Sr.)

the power to provide
commercial marine insurance and programs



- Shipyards
- Tow Boats
- Passenger Vessels
- Contractors & Salvors

Headquarters: 16 Main street, East Greenwich, RI 02818 | 800.232.0582 x 182 | rcarnahan@gencorp-ins.com

Leadership Edition

hailed cargoes up into Alaska. So we took those barges into Asia and now they're on a six month contract over there." Yet another challenge is new emissions regulations and the rising cost of fuel. "We've got more regulations coming along on air emissions. We're exploring ways we can meet the requirements in the ECA zone which is basically surrounding the U.S., and all of North America, for that matter. We can't burn the types of fuels we've been burning in medium-slow speed engines. We have to switch to low sulfur and lower particulate fuels."

"The real crux in the industry is going to be the cost of fuel," Crowley said. The new emissions requirements are "going to increase the cost of diesel across the board. Any refined product is going to become more expensive because the demand for refined products is going to go up greatly over the next five years. So it basically raises the cost of doing business. In the environment we find ourselves in, that's a tough combination — to have the top

line under pressure and the cost under pressure at same time." However, Crowley said, "I think we're fairly well positioned to weather the storm. We've invested heavily in new technology and new vessels. We have dual fuel capabilities. We've known this was coming and we want to be ahead of the curve." The new double hull barges Crowley recently christened for Western Alaska and the double hull ATB fleet nearing completion are part of Crowley's continuing fleet upgrade. "We've been able to keep the equipment chartered and able to deploy it in new markets." In addition, Crowley said, "we've got some new offshore tugs under construction that will be much more powerful than the tugs we currently have. These are zero discharge vessels, able to contain their own waste water and travel 30 plus days under full load." These new Ocean Class vessels are 10,000 hp with a bollard pull of at least 150 tons. Delivery of the first in the series is expected by the end of 2011.

A rendering of Crowley's Ocean Class Tug



Images courtesy Crowley Maritime Corporation

Serious Air For Serious Places

Confined
Space Air
Ventilators

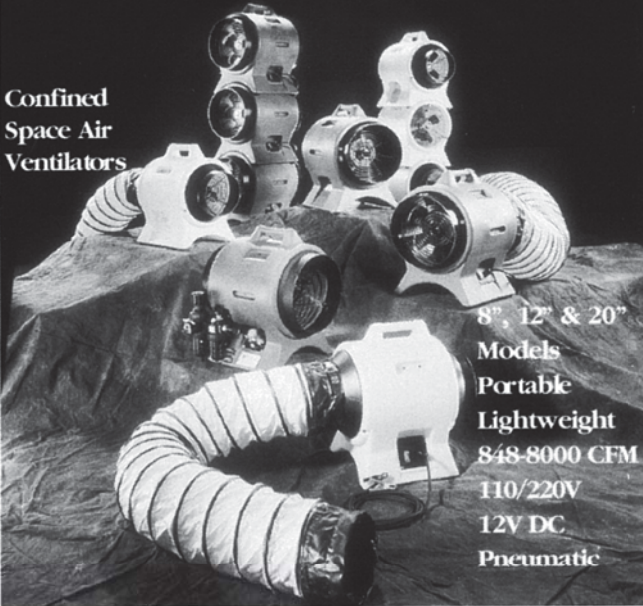

8", 12" & 20"
Models
Portable
Lightweight
848-8000 CFM
110/220V
12V DC
Pneumatic



Americ Corporation

785 Bonnie Lane
Elk Grove Village, IL 60007
For more information, call 800-364-4642
or Fax 847-364-4695

www.americ.com

Braking Solutions

For:

Marine Propulsion
Bow Thrusters
Suction Dredgers
Compressor Drives
Fan Drives
Diesel Pumps
Main Propulsion
Pump Drives
Marine Pumps



Hilliard

100 West 4th St.
Elmira, NY 14901
607-733-7121

www.hilliardcorp.com
hilliard@hilliardcorp.com

TUTOR-SALIBA CORPORATION

Contact: James Foster
818-362-8391

EM1068 Official # 534891 - 1021 net/Gross Tons -
Built 1928 in Oakland CA. LOA 258.5' - Beam 38'
- Depth 12'. Flat Deck Barge, riveted steel con-
struction, raked bow and stern. 6" asphalt wear
deck with 3' steel fenced sides running port and
starboard. Barge is also outfitted with 2 Clyde two
drum waterfall winches. **\$300,000.00.**

EM1163 - 125' x 34' x 9' Flat Deck Barge s/n
1065170 c/w 12 hatches, 4 bits, 6 kevels, 25
degree raked bow/stern, stern w/skaggs.
\$125,000.00.

OFTEN IMITATED,

NEVER

DUPLICATED.

EXPERIENCE. . .

50 years evidenced in over
1700 vessels designed and built.

THE VERSATILITY. . .

As exemplified in
Breux's Bay Craft, Inc. constructed
crew boats, passenger vessels, excursion vessels,
catamaran, pilot vessels, and motoryachts
in use around the world.

AND QUALITY. . .

The fairest of hulls,
CUSTOM BUILT to meet
any type of service required.

Breux's
BAY
CRAFT

INCORPORATED

(Founded by Roy Breux, Sr., 1946)

For Additional Information Contact:
Roy Breux, Jr. or Hub Allums
P.O. Box 370, Loreauville, LA 70552
Phone (337) 229-4246 or FAX (337) 229-8332

Veolia

James Parker, GM, Offshore Division

James Parker became General Manager of the offshore marine division of Veolia ES Special Services in 2007. Veolia's marine services began on the inland side and expanded into the offshore market several years ago, Parker said. "That was just prior to the hurricanes coming through the Gulf, Katrina being the first one, that tore up the infrastructure. It allowed Veolia an opportunity to break into the market when the market was very hot. It expanded from offering basic diving services, to saturation diving, to remote operated vehicle services. Then we acquired a couple vessels and grew from there."

"Up until this point we have been primarily focused in the Gulf of Mexico. With the BP incident in the Gulf of Mexico, it rather dramatically effected our market and its still uncertain how fast it will recover. Eventually we expect it to return to pre-Macando levels, but we don't

really know when that will be." The state of the Gulf market may slow down Veolia's offshore marine division growth curve, or rate of personnel and capital acquisitions, "so we don't outstrip the market," Parker said. "As demand grows in the market, we will grow to meet that demand."

As far as moving to international markets, "we don't have any intent to reduce our presence in the Gulf of Mexico," said Brent DuBois, Director of Business Development at Veolia. "But we do have a plan forward to pursue increasing our presence in other markets."

Veolia's current projects in the Gulf of Mexico include contracts with Chevron and Petrobras.

"We have an ongoing project with Chevron, the Hurricane Restoration Team project. We're going in and cleaning up the mess the hurricanes made. Chevron has

GM, Veolia Offshore

James Parker

"Up until this point we have been primarily focused in the Gulf of Mexico. With the BP incident in the Gulf of Mexico, it rather dramatically effected our market and its still uncertain how fast it will recover. Eventually we expect it to return to pre-Macando levels, but we don't really know when that will be."



Images courtesy Veolia ES

been one of the leading contractors in the Gulf of Mexico as far as cleaning up the messes the hurricanes leave behind. We've been doing that for about four years, constantly. It's been a highly successful project for both Veolia and Chevron," Parker said.

Veolia's clean-up work includes the preliminary site surveys of the subsea area where platforms have been knocked down by a storm, connections of the massive amounts of rigging that are necessary to lift the structures from the sea bottom and the diving support work that goes with actually lifting of the structures and placing them on barges.

Veolia's 340-ft offshore construction vessel Swordfish was being built when Veolia began talking with Chevron about the project. Veolia made some modifications to the newbuild, including adding a second crane, so that it met Chevron's need. "That's why its been working on that project for Chevron for such a long time," said Brent DuBois. "It has a thousand-ft saturation system, two ROVs, a 150 ton crane, as well as a 70 ton heave compensated crane, which makes the vessel rather unique in

the marketplace and ideally suited to perform the hurricane work."

"Our other flagship project that we're very pleased with is the Petrobras Cascade Chinook project," said Parker. "The Petrobras project is in 3,000 meters of water (ultra-deep water) and it involves infrastructure in the Cascade Chinook field which is unique because it's the first application of a floating production storage and offloading unit (FPSO) in the Gulf of Mexico."

Parker described some of the infrastructure work Veolia has performed on the project. "We've installed jumpers on the subsea architecture and we've installed flying subsea leads. We've done a large amount of subsea survey work for the installation of the different components. We did the pull-in connections for the hybrid risers onto the turret buoy that's actually connected to the FPSO."

The 426.5-ft Viking Poseidon, which features the Ulstein X-Bow design, has been the primary vessel for this project. The benefit of the X-Bow design is better sea keeping capability in dynamic positioning mode and less pitch effect in heavy weather.

**DIVERSIFIED
Engine Exhaust Systems**



ABS Certified Bureau Veritas Qualified



HAPCO
ENGINE AND
ENVIRONMENTAL
PRODUCTS

HARCO MANUFACTURING CO.
1000 Industrial Pkwy • Newberg OR 97132
800-394-7571 Fax: 503-537-0601
www.harcomanufacturing.com
email: sales@harcomanufacturing.com

The first name in maritime training

Mariner career training and industry learning
backed by over 130 years of tradition.

Maritime College Professional Education & Training offers traditional and online training opportunities to professional mariners and nautical enthusiasts.

- Basic and Advanced Firefighting
- Bridge Resource Management (BRM)
- Automatic Radar Plotting Aids (ARPA)
- Radar (Original and Renewal)
- Basic Safety Training (BST)
- Able Seaman (AB)
- Lifeboatman/ Proficiency in Survival Craft (PSC)
- Tankship Person in Charge (PIC)
- 100 Ton, 200 Ton, Limited Master/OUPV
- Electronic Chart Display and Information Systems (ECDIS)
- International Ship and Port Security (VSO, FSO, CSO)
- Global Maritime Distress and Safety System (GMDSS)
- Online Marine Surveying Programs
- Flashing Light
- RFPNW Assessments
- First Aid and CPR
- Celestial Navigation

Both contract and scheduled training available.
For more information, call (718) 409-7341 or
go to www.sunymaritime.edu for more details.



MARITIME COLLEGE STATE UNIVERSITY OF NEW YORK

VESSELS

Bollinger Builds Tank Barge No. 250 for Bouchard

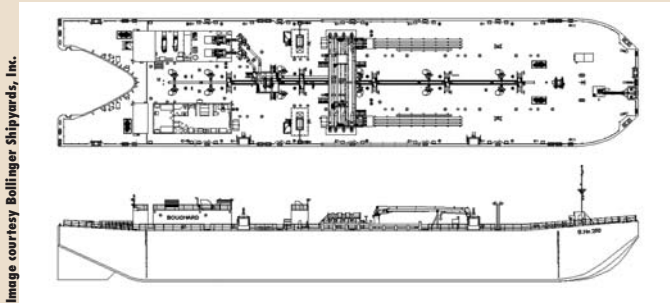

Image courtesy Bollinger Shipyards, Inc.

Bollinger Marine Fabricators, LLC, Amelia, La., a Bollinger Shipyards, Inc. company, has signed a contract for the new construction of a 55,000 barrel OPA '90 compliant tank barge with Bouchard Transportation Co., Inc., Melville, N.Y. The vessel is a manned ocean service, clean oil barge measuring 317.5 ft long, with a 70-ft beam and a depth of 28 ft. The B. No. 250 is a new design especially engineered for Bouchard, built and certified by American Bureau of Shipping (ABS) and the United States Coast Guard (USCG). It has twelve cargo compartments and two separate pumping systems, capable of transporting grade A and lower petroleum products. B. No. 250 will be fitted with an Intercon coupling ladder system, dual pump ballast system, two Techcrane hose handling cranes and Coastal marine anchor and mooring winches.

U.S. Barge Combo Deck Tank Barge

U.S. Barge LLC, a wholly-owned subsidiary of Vigor Industrial LLC, delivered a combination deck and tank barge to NorthStar Gas LLC, an Alaskan Petroleum Distributor. NorthStar Gas and its operating partner, Delta Western, will use this barge to service customers in Western Alaska, stabilizing the transportation costs of fuel in the region. Barge Cauneq is capable of carrying up to 200,000 gallons of fuel plus deck freight in waters tributary to the Bearing Sea, Chukchi Sea and Arctic Ocean.



Photo courtesy Elliott Bay Design Group

The barge has been certified by the U.S. Coast Guard for carriage of Grade B and lower petroleum products and complies with OPA '90 requirements. The main deck is over 3,000 sq ft and can accommodate a minimum of seven ISO standard containers. Barge Cauneq measures 162 ft by 44.5 ft with a depth of only six ft. The shallow-draft design allows the barge to navigate in waters as shallow as three ft. The engineering and design was performed by Elliott Bay Design Group of Seattle, Wash.

BCGP Delivers Two RHIBs to Jordan



Photo courtesy BCGP

Brunswick Commercial and Government Products (BCGP), a division of Brunswick Corporation, recently delivered two 750 Impact rigid hull inflatable boats (RHIBs) to the country of Jordan. The boats will be used for dive and rescue operations. The two RHIBs are each powered by a Cummins 5.9L 355 hp inboard diesel engine and propelled by Ultra Jet 305 water jets. They feature a hydraulically-actuated dive door designed to easily bring injured divers on backboards into the boat for medical attention and transport. The dive door was developed by BCGP's engineering team and is a patent-pending new option available on all BCGP Impact RHIBs. The boat also features a reinforced stainless steel gun mount at the bow for a 7.62mm firearm. At the aft end of each boat, a full-length aluminum swim platform doubles as a jet guard. A FLIR infrared night vision camera is mounted on the T-top.

Alpine Ocean Seismic Survey Launches RV Shearwater

Alpine Ocean Seismic Survey announced the launch of the multi-use research vessel Shearwater. The addition of this new vessel allows Alpine to expand its offerings of turnkey data collection and other surveying services to offshore clients, including wind, tidal, civil engineering, shoreline protection, pipeline, oil, and natural gas project

Photos courtesy Harris Media Services



developers. The Shearwater has a shallow draft of 6.5 ft and the aluminum twin hull measures 110 ft by 40 ft. It offers superior positioning and line-keeping performance, hydraulic propulsion for fuel-efficiency and excellent maneuverability as well as reduction in vessel noise. The Shearwater can accommodate up to 20 people on a 24-hour basis. Since its March commissioning, the vessel has completed several projects on the Gulf and East Coasts for clients including the U.S. Army Corps of Engineers and the N.J. Department of Environmental Protection.

Trinity's 191-ft Carpe Diem Delivered

Trinity's newest superyacht, the 191-ft trideck motoryacht Carpe Diem, has been delivered to her owner, a repeat Trinity client. The vessel is the second hull in the new series and features aluminum construction and a 33-ft beam. The Carpe Diem's interior was designed by Carol Williamson & Associates and features a large sky lounge, swim platform and customized "tenders and toys." Carpe Diem has a cruising speed averaging 18.5 knots and an eight-ft draft. Carpe Diem features a main deck full-beam king master suite with and guests have a full-width aft king VIP lower deck stateroom with four additional staterooms. For flexibility the two forward guest staterooms are easily converted to an additional full-width forward king VIP. Crew quarters provide direct access to guest staterooms and a private crew stairway leads to the galley and the pilothouse level. Carpe Diem accommodates an owner's party of 12 in six staterooms and 12 crew in six cabins.



Crowley Builds DH Petroleum Barges for Alaska

Crowley Maritime Corporation christened two new double-hulled petroleum tank barges, the 165-1 and 165-2, on May 7 during a small ceremony at Dakota Creek Industries in Anacortes, Wash. The vessels, which are the first double-hulled, environmentally friendly barges of their kind to operate in Western Alaska waters, will join Crowley's 180-1, a double-hull barge that has serviced Alaska since 2005. Vessel sponsors Janis Ivanoff, president of Norton Sound Economic Development Corporation, and Debra Shontz, director, Barrow operations for Arctic Slope Regional Corporation, performed the christening. Twenty guests, including friends and employees from Crowley and its Jensen Maritime subsidiary, attended the event. The 165-1 and 165-2 are homeported in Nome, Alaska. The double-hull barges will be used for shallow-draft operations and beach landings for the delivery of fuel and cargo to the remote communities of Western Alaska.

Improve your view of what's ahead.
Call: JMS

- Engineering And Design
- Marine Casualty Response
- Marine Survey And Inspection
- Port Engineering Services

JMS
NAVAL ARCHITECTS
SALVAGE ENGINEERS
JMSnet.com · 860.536.0009

New! >  

JMS applications for your iPhone.
U.S. Navy Salvor's Handbook
Go to > www.JMSnet.com

MARKETS

Simrad Yachting Launches Broadband 3G Radar



Simrad Broadband 3G Radar

Simrad Yachting launched its next-generation, solid-state Broadband 3G Radar. Delivering two-times greater RF transmit power and 30% more range and target detection than the BR24, the 3G allows mariners to see objects such as small boats and channel markers at greater distances without compromising its close-range radar capacities. The Broadband 3G Radar offers clear, detailed views of surroundings at a range scale down to 200 ft and marks objects within 6.5 ft of the boat. The new radar transmits 1/10,000 the power of traditional pulse radar — less than a fifth the energy of a mobile phone — making it safe to install just about anywhere on a boat. It is also 30 to 50% more efficient than traditional pulse radomes. Broadband 3G Radar supports chart overlay, display networking, MARPA and True Motion Radar Display to distinguish moving vessels from fixed objects or landmasses. Drawing 18 watts of power during operation and two watts in standby, the Broadband 3G has an operating temperature range of -13 to +131 degrees Fahrenheit and can operate in winds up to 100 knots.

PortVision's TriMode Workboat Fleet Service

PortVision announced its PortVision TriMode workboat fleet management and business intelligence service. The web-based solution extends the company's AIS-based offering to include two-way cellular and satellite service for messaging and position reports, and uses least-cost routing to cut overall expenses. The TriMode service integrates least-cost routing across three communication paths, including AIS for real-time reporting of the fleet and other AIS-enabled vessels when near shore or in-port, cellular for near-real-time reporting at very low cost when-

ever a vessel is within a cellular coverage area and satellite for guaranteed reporting and text messaging whenever cellular is unavailable. Users can use the TriMode service to create e-mail alerts, view arrival/departure history and tap into PortVision's data warehouse, which processes 40 million vessel positions daily and archives over 15 billion arrival, departure and vessel movement records spanning the last five years.

Telaurus Onboard Wi-Fi Connectivity

Telaurus Communications has successfully completed trials of its Wi-Fi service onboard ships equipped with se@COMM. Crew communications — particularly SMS and email services — have become an essential service for shipowners and managers serious about crew welfare. Evidence from seafarers suggests that communication with loved ones while at sea not only improves morale and the overall productivity, it can make the difference between crew staying with the fleet or signing off. But while crew communications packages are proliferating, they come with technical challenges. Crew communications must be kept separate from ship's business and there is a need to put the connectivity where the crew can use it safely — in the mess or other communal areas. Telaurus has addresses this by installing a wireless access point on ships equipped with its se@COMM service to deliver wireless connectivity to seafarers, accessible via their smartphones or laptop PCs. With the use of an extendable antenna unit the connections can now bridge multiple compartments without sacrificing bulkhead integrity and without interfering with ships' business.



Telaurus WiFi iPhone

Falling Short: Hearing on Maritime Jobs

Shoehorned into a narrow one-hour slot immediately preceding the Israeli Prime Minister's speech to Congress, the (feigned) importance of U.S. maritime regulatory policies became all-too-obvious during a subcommittee hearing largely comprised of grandstanding by various house members. It is, therefore, business as usual inside the beltway; at least for domestic maritime stakeholders.

Weeks ago, when the House Subcommittee on Coast Guard and Maritime Transportation announced the "Hearing on Creating U.S. Maritime Industry Jobs by Reducing Regulatory Burdens," maritime industry stakeholders probably felt that they were being taken seriously by our elected officials in Washington. In the wake of that hearing — which, gavel-to-gavel, lasted just 60 minutes — these same folks were likely left wholly unsatisfied. Before departing for what was clearly an important and historical speech elsewhere, however, house subcommittee members got their licks in on U.S. Coast Guard RADM Kevin Cook and Calvin Lederer, Coast Guard Deputy Judge Advocate General. Little more than that was accomplished.

Cook and Lederer kicked off the hearing with short, five-minute statements that focused on some of the positive things that were being achieved within DHS, including the claim that the development and implementation of the typical Coast Guard regulation — aside from security-related mandates — added little in the way of burdens to industry. Cook also pointed to a 50% increase in regulatory staff (to 82 full-time billets) that had helped to reduce the

average rulemaking time by as much as 12 months. He added that active rulemaking initiatives in play had been reduced from 78 to 60 in the wake of the addition of congressionally authorized staff and that half of those remaining regulatory issues were in fact driven by statutory requirements. Lastly, Cook acknowledged that industry and the general public alike continue to struggle with the regulatory burden.

It was at this point where the meeting turned into a largely complaint-driven recitation of regional laundry lists consisting of pet peeves by subcommittee members who came and went as they pleased; some not bothering to come at all and others arriving more than 30 minutes late. Many regulatory initiatives were highlighted by the members for one reason or another, including:

- Determination of foreign-built hulls (as relating to Jones Act trades)
- Determination of seafarer's medical fitness for employment afloat
- Deteriorating expertise of Coast Guard marine safety and technical personnel
- New regulatory burdens on fishing guides in Minnesota and other local matters
- OMSA complaints about confusing and complex "notice of arrival" requirements
- Ballast Water Treatment (BWT) final rule
- The effect of new Coast Guard regulations limiting passenger loads because of "average weight" determinations
- Fishing Vessel Safety Examinations
- Cruise Vessel Safety & Security Act

All of that was crammed into 60 minutes, including subcommittee chair statements, witness testimony and various displays of eye-rolling and dramatics by various members of the subcommittee. For the record, it took me substantially longer to recap the hearing and write this column. All of it is important; none of it got solved and the vast majority of it was touched upon in the most superficial of ways.

*Excerpted from a
MaritimeProfessional.com post
by Joseph Keefe*



SHACKLES — "GOLD STANDARD", forged from the finest alloy steel. Available all styles. Safety pin available in capacities up to 210 ton.

FAIRLEADS — Timken bearing equipped. Deck and flange mounted. 4" through 48" sheave diameters. Roller fairleads also available.

BLOCKS — All bearing types available. 4" through 36" models, capacities 5 ton through 75 ton for single sheave styles. Capacities up to 500 ton in multiple sheave models.

SHEAVES — Choice of manganese or cast steel, all types of bearings.

Stock or Custom Engineered
Proved dependable throughout the world — in the roughest, toughest applications

Call for FREE Catalog: 1-800-547-8211 • www.skookumco.com

PEOPLE & COMPANY NEWS



Dixon

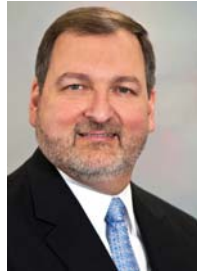

Martin



Hume



Guidry



Hatchell

Mike Ray Dixon Passes Away

Mike Ray Dixon, 67, of Katy, Texas, passed away April 25. Dixon won numerous national awards as an editor of corporate magazines and annual reports when he worked for Fortune 500 companies during a 40-year career as a public relations official. These companies included Phillips Petroleum, Kerr-McGee, Williams Companies, Texas Oil & Gas, Marathon Oil and U.S. Steel.

Cornel Martin Departs WCI

Waterways Council, Inc. (WCI) President and CEO, Cornel Martin, has announced that he will depart the organization at the end of June. An executive search will begin to identify a successor. Cornel joined WCI with many years of experience in the maritime industry including years on Capitol Hill where he last served on the House Coast Guard and Navigation Subcommittee.

Hume New W&O CEO, Guidry Advances in Pon

W&O, supplier of marine valves, pipe, fittings, engineered products and valve automation systems, appointed Michael Hume as President and CEO. He has been serving as the company's COO since 2009. Jack Guidry, former president and CEO of W&O, has been promoted to Senior VP of Pon and CEO of PVI, one of Pon's American holding companies, which owns W&O,

DMC-Carter Chambers and AT Controls.

Hatchell Joins DLBA

Gordon Hatchell has joined Donald L. Blount and Associates, Inc. (DLBA), a naval architecture and marine engineering company. Previously, Hatchell served as Supervisor and Program Manager for the Special Projects Branch, Combatant Craft Department of Naval Surface Warfare Center, Carderock (NSWCCD).

VT Halter to Build 112-ft ATB Tug

VT Halter Marine, Inc. announced a new contract to build a 112-ft ATB offshore tug for Bouchard Transportation Co., Inc. This tug will be similar to others built for Bouchard in previous years by Halter Marine. Measuring 112 ft by 35 ft by 17 ft, the 4,000 hp tug is classed by ABS as A1 Towing Vessel, Dual Mode, and will be equipped with an Intercon Coupler System. Construction of the vessel begins in June 2011 at VT Halter Marine's Moss Point Marine facility in Escatawpa, Miss., with delivery expected in September 2012. The vessel will enter into Bouchard's fleet service in New York, N.Y.

Trans-Alaska Pipeline, Crowley Workers Reach 10 Million Hours

The Trans-Alaska Pipeline System (TAPS) has announced that its work-

force has achieved a major safety milestone: 10 million hours worked without an OSHA Day Away From Work Case (DAFWC). Of those hours, Crowley contributed towards working 20% of them, or two million hours, safely. This means that since June 2009, no TAPS worker, including the more than 225 Crowley employees, has been injured to the extent that they missed a day of work. For more than 30 years Crowley has provided tanker escort, response ship assist and vessel operations for TAPS operator Alyeska Pipeline Services Co. in Valdez, Alaska. The safety milestone is especially significant considering a majority of these employees work in the field and in environments with cold weather and heavy sea conditions.

ABS Guidance For New Generation OSVs

Increased sophistication within the offshore support vessel (OSV) market has prompted classification society ABS to develop standalone guidance for these more specialized yet multi-functional vessels. Newly developed criteria and relevant existing Rule



Photo courtesy of POSH Seamo Pte Ltd.

PEOPLE & COMPANY NEWS

requirements have been consolidated into the ABS Guide for Building and Classing Offshore Support Vessels. The OSV Guide consists of four major sections: scope and conditions of classification, hull construction and equipment, machinery and systems and offshore support services. Material and welding, strengthening for navigation in ice and survey during and after construction are referenced from the ABS Rules for Building and Classing Steel Vessels. The intent is to evolve the ABS Guide for Building and Classing Offshore Support Vessels into Rules during the society's next Rule making cycle. Included in the OSV Guide are explanations of notations reflecting specialized capabilities such as transportation of supplies and equipment, towing and anchoring of offshore structures, fire fighting, diving, oil spill recovery, safety standby rescue, pipe laying, handling heavy surface and subsea loads, well intervention, well stimulation, well test and wind farm support.

Crowley Recognized for Environmental Stewardship

Crowley Maritime Corporation was recently recognized for its environmental stewardship by the Port of the Seattle and Seattle Propeller Club, which teamed up to present the company with its second-consecutive honorable mention award for Marine Environmental Business of the Year. The awards ceremony took place at

the 60th Annual Maritime Festival Luncheon aboard Holland America's cruise ship Zaandam in Seattle. The event, attended by more than 500 people from the regional maritime industry, marked the culmination of Seattle's annual Maritime Festival. Scott Hoggarth, Crowley general manager, ship assist and escort services, accepted the award on behalf of the company.

BOEMRE New Regional Director

The Bureau of Ocean Energy Management, Regulation and Enforcement (BOEMRE) named Dr. James Kendall as the Director of the Alaska Outer Continental Shelf Region. Dr. Kendall has been serving as the Acting Director for the region since January 1, 2011. Dr. Kendall most recently served as the Chief of BOEMRE's Environmental Division.

Affordable Luxury When You're Anchored in Boston

The antiquity and charm of the original Mariners House has been updated to include all the modern amenities, featuring completely renovated private rooms, private baths, elegant common rooms and all the in-room necessities of modern life. Rediscover us.

Starting at

\$65

per night including breakfast. Lunch and dinner offered daily. Guests must be active seafarers with proof of service.

MARINERS HOUSE
160 Years of Hospitality and Guidance
to Professional Mariners

11 North Square, Boston, MA 02113
Voice (617) 227-3979 Fax (617) 227-4005
inn@marinershouse.org www.marinershouse.org

To Make a Reservation, call 1-877-SEA-9494



Photo courtesy Crowley Maritime

PEOPLE & COMPANY NEWS

FDNY Marine Ops' New Travelift



Photo courtesy Marine Travelift

The New York City Fire Department (FDNY) is the largest fire department in the U.S. and protects 560 miles of waterfront with a fireboat fleet. To increase its boat haul-out abilities FDNY Marine Operations opened up a competitive bidding process for a new mobile boat hoist. Marine Travelift won the new account with its 50 BFMII mobile boat hoist and delivered it in September of 2010. The most common vessels the FDNY transports

range from 25-ft open center console vessels to 27-ft full cabin crafts, up to and including its new 65-ft fireboat that weighs approximately 88,000 lbs. FDNY's Marine Operations chose a new mobile boat hoist that offered the capability to perform lifts with slings and a special spreader with "pick points" for the vessels with foam collars, including its foam-stabilized SAFE Boat.

Weeks Marine to Build Ocean Going Dredges

Weeks Marine Inc. (WMI), based in Cranford, N.J., announced two major additions to its fleet. By the end of 2011, the Weeks 315, a new ocean class, 30-inch, hydraulic cutter suction dredge will join Weeks Marine's large and diverse pipeline dredge fleet. Approximately two years later, a new large class, 8,500 cubic yard hopper dredge, the Weeks 475, will become WMI's third hopper

dredge. The Weeks 475 will be WMI's largest, fastest, most fuel efficient, most powerful pumping and most highly automated hopper dredge. The dredges doubles WMI's current hopper dredge capacity, are designed specifically for conditions found offshore of the U.S. coast, and are part of WMI's three-year, \$200m plus capital investment program in five vessels. Construction of the Weeks 315 is currently underway in an Ohio River shipyard and completion is scheduled for an end-of-year delivery. The Weeks 475's engineering package was developed jointly by WMI and IHC Merwede. The keel is scheduled to be laid in October, 2011. Both vessels will be equipped with EPA tier II engines and will feature state-of-the-art AC drives to power the pumps, winches, cutter, jetting and other systems, all of which will be controlled by fully integrated and advanced automated systems.

JMS Acquires Research Vessel Design Firm

JMS Naval Architects & Salvage Engineers (JMS) acquired Roger Long Marine Architecture Inc. (RLMA). The acquisition includes exclusive rights to RLMA's Challenger class fast research vessels. Roger Long, RLMA's founder and principal designer, will become a senior design consultant to JMS' research vessel design projects. The RV Gulf Challenger was designed and built in 1993 for the University of New Hampshire and demonstrated that a small, fast research vessel can offer slow-speed efficiency and comfort equal to, or better than, heavier displacement vessels. Follow-on vessels in this series include the RV Fay Slover, selected as one of the 10 most significant vessels of the year by American Ship Review, the RV Tioga owned by Woods Hole Oceanographic Institution, and most recently, the 81-ft RV Rachel Carson launched in 2008 and owned by the University of Maryland. With a pair of 1,200 hp jet outdrives, the RV Rachel Carson cruises at 24 knots allowing researchers more time on station and less time in transit.



Photo courtesy JMS Naval Architects & Salvage Engineers

Italian Guardia di Finanza Selects Raymarine



Courtesy FB Design Carlo Borlenghi 2

Nine new vessels designed by race boat driver and designer Fabio Buzzi and fully equipped with Raymarine electronics, have been delivered to the Guardia di Finanza, the militarized customs and border patrol service responsible for preventing financial crime and smuggling in Italy. The nine boats comprise four FB38 (38 ft) models with extended cockpit, four FB38 with smaller cockpit and enlarged forward deck area and one FB43 (43 ft). Each boat has been fitted with an integrated suite of Raymarine electronics, with a large color multi-function display showing radar, GPS, digital sonar and chart data.

Viking Pump Historical Museum Celebrates 100 Years

In honor of their 100-year anniversary, Viking Pump has created a historical museum highlighting the unique innovations on which the company was founded. The museum starts with the Granddad pump, the original created 100 years ago, and flows through to current applications, literature and pumping innovations. Complete with artifacts through the years and interactive displays, this museum is designed to engage all visitors with a mixture of history and current technology.

NSRP Awards \$14.6m New R&D Projects

The Executive Control Board of the National Shipbuilding Research Program (NSRP) has awarded funding for six new research and development projects to continue the program's mission to reduce the costs associated with U.S. shipbuilding and ship repair.

First Time Quality, Non-Destructive Examination & Fitness for Service Technology for Friction Stir Welding & Manufacturing Aluminum Panels for Ships

Project Lead: Bollinger Shipyards

Team Members: Ingalls Shipbuilding, Marinette Marine, Austal USA, Alcoa, Naval Surface Warfare Center Carderock, Gatekey Engineering, American Bureau of Shipping, V. Dlugokecki, Hepinstall Consulting, Friction Stir Link, Concurrent Technologies Corporation, Edison Welding Institute, Manufacturing Technology Inc., Tabor Industries

Objective: To develop best practices to achieve first time quality using Friction Stir Welding for different combinations of alloys, joint designs and thicknesses. New non destructive examination processes will also be developed and tested for weld evaluations.

Program Funding: \$3.3M Industry Cost Share: \$2.2M

Swaged Bulkhead Analysis Verification - Project Lead: GD NASSCO

Team Members: Marinette Marine, University of California at San Diego

Objective: Develop, validate by test and refine for efficiency analytical FEA methodologies that will support structural engineering/design of swage bulkheads in ships. Paint adherence will also be tested and compared to stiffened bulkheads.

Program Funding: \$935K Industry Cost Share: \$777K

This program is managed and operated by: Advanced Technology International

Elimination of Over Welding to Reduce Distortion in Naval Shipbuilding Applications

Project Lead: Ingalls Shipbuilding

Team Members: Applied Thermal Sciences, Concurrent Technologies Corporation, University of New Orleans, University of Maine, Naval Surface Warfare Center Carderock

Objective: Develop an optimization process on weld size control and production process improvement, intended to significantly reduce the cost of lightweight steelwork production.

Program Funding: \$1.7M Cost Share: \$1.4M

Reduction of Total Ownership Costs Through Application of Design For Maintenance & Repair Methodologies - Project Lead: Bollinger Shipyards

Team Members: BAE Systems SE Shipyards, Todd Pacific, GD Electric Boat, Trident Refit Facility Kings Bay, Naval Surface Warfare Center Carderock, Matt Tedesco, Hepinstall Consulting Group, V. Dlugokecki

Objective: To develop a comprehensive Design for Maintenance (DFM) product (methodologies, repair standards and design templates) that focuses on reducing life cycle maintenance costs by enabling more efficient installation and replacement.

Program Funding: \$1M Industry Cost Share: \$840K

Naval Vessel Ice Capability Optimization Effort - Project Lead: GD NASSCO

Team Members: GD Bath Iron Works, American Bureau of Shipping

Objective: To develop analytical methods and templates to meet a range of Ice Capability requirements for a variety of generic ship types/classes. Results will be independently reviewed and validated by ABS.

Program Funding: \$912K Industry Cost Share: \$912K

21st Century Smart Weld Inspection to Improve Ship Performance

Project Lead: Servo Robot Corp.

Team Members: Ingalls Shipbuilding, Newport News Shipbuilding, Marinette Marine

Objective: Develop a portable weld inspection tool optimized for shipyard weld joints and applicable weld quality standards. The project will improve the existing Servo Robot WikiScan portable weld inspection tool and the Portable Weld Inspection Management System (PWIMS).

Program Funding: \$456K Industry Cost Share: \$364K

PRODUCTS

Kvichak's New Facility: Flashmark Tech

Kvichak Marine Industries was a recipient of an ARRA small shipyard grant awarded in 2009. One of the improvements funded by this grant was a new cutting table and brake which the company has located in a newly leased facility located in the South Park area of Seattle. Flashmark Tech, a division of Kvichak Marine, is now in full production. This new facility has a 16-ft 325 ton 2 Axis CNC Press break and a 10-ft by 60-ft speed router table with integrated Galvo laser marking system which provide Kvichak the ability to control the schedule of its cut parts being delivered to the production floor.



Photo courtesy Kvichak

www.kvichak.com

The HyperSizer Composite Analysis Tool

Collier Research Corporation released its HyperSizer v6 structural sizing and analysis software for reducing weight, maintaining strength and improving the manufacturability of complex composite and metallic designs. Developed and proven at NASA, the software — the first ever commercialized by the agency — has a track record of 20 percent weight reduction in high-profile government and commercial aerospace projects. In addition, HyperSizer's design and manufacturing capabilities are appropriate for optimizing composite-driven designs in a wide variety of industries including ship superstructures.



www.hypersizer.com

Rustibus Scaling Machines

Rustibus scaling machines are based on a patented rotating chain link system that provides more than 200,000 blows per minute depending on the machines size. Rustibus machines have a capacity of approximately 200 to 300 sq ft per hour with a resulting surface in accordance with SP 3 + (SSPC-SP11++). U.S. facilities offer rental services. The most



Image courtesy Rustibus

recent Rustibus machine is a heavy-duty electric hand tool, ideal for spot scaling on small horizontal and vertical areas.

www.rustibus.com

Remote Voltage Control XMT WCC System

Miller Electric Mfg. Co. introduced the XMT Weld Cable Control (WCC) System: the matching of an XMT 350 or XMT 456 multiprocess welding inverter with a voltage-sensing SuitCase X-TREME WCC wire feeder and a WCC control. This MIG/Flux cored welding system allows welders in the construction and shipbuilding industries, who often work more than 100 feet away from the welding power source, to adjust voltage settings at the point of use. Adjusting voltage at the point of use reduces the need to leave the work area and travel back to the power source. The system is also available with Dimension NT multiprocess welder.



Images courtesy Miller Electric Mfg.

www.millerwelds.com

VertaJet SRT-6LT for Surface Prep

The VertaJet SRT-6LT from NLB Corp. accomplishes surface preparation faster than manual water jetting and is even more ergonomic than previous models. The new handheld unit needs no air connection to rotate the 40,000 psi water jets and it weighs just 20 lbs. The VertaJet SRT-6LT quickly removes paint, epoxies and other coatings from steel structures and other surfaces. Multiple water jets rotating at 3,000 rpm create a six-inch cleaning path.

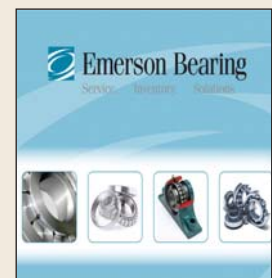

Photo courtesy NLB Corp.

www.nlbcorp.com

Emerson Bearing's New Product Catalog

Emerson Bearing, catering to OEM (Original Equipment Manufacturers) and MRO (Maintenance, Repair and Operations) markets worldwide, announced a new product catalog. Emerson Bearing has converted their online product



catalog into a 210-page print catalog. The free catalog is available upon request. Call Emerson Bearing at 800-225-4587.

www.emersonbearing.com

Coxreels New Diesel Exhaust Fluid Hose Reels

Coxreels introduced a complete line of Diesel Exhaust Fluid (DEF) hose reels built on the all-steel construction SH and T Series reels. These reels are equipped with a stainless steel external full-flow swivel and chemical resistant Viton seal to provide a safe, reliable DEF dispensing solution. The swivel is easy to access for simple seal maintenance and fast DEF dispenser hose installation. Coxreels provides professional reeling systems in heavy-duty single pedestal (SH Series) or supreme-duty dual pedestal (T Series) configurations that handle DEF hoses up to 75 feet of three quarter inch and up to 50 feet of one inch. Both designs are outfitted with Super Hub dual axle support systems to increase stability and reduce vibration during operation.

www.coxreels.com



Digital Yacht America's AIS Antenna

Digital Yacht America launched the AA10 antenna which is specifically designed to operate with AIS systems. The white quarter wave whip antenna measures 21 inches. It is designed to fit a standard, one-inch GPS antenna style mounting, so it can be fitted on to the pushpit rail, mast top or wheel house roof. It comes with a 33-ft cable fitted with a solder-less connector, no thicker than the wire itself.

www.digitalyachtamerica.com



Image courtesy Digital Yacht America

DataLog Fuel Monitoring Software for FloNET

FloScan's new PC software, DataLog, records fuel usage data for NOx emissions reporting and simplifies fuel inventory control. DataLog also provides real-time fuel flow data to pinpoint the engine speed to improve fuel economy by 20% or more. Individual supply and return fuel flow rates and temperatures keep track of the engine's

health and performance. Changes in these parameters under normal operating conditions, such as a reduction in the supply flow rate or a marked increase in the return flow temperature, are a clear indication that something is amiss. Models are available for all makes of marine diesel engines up to 6,000 hp.

www.floscan.com



Image courtesy RaceMate Inc.

Delta System's New Head Vent System

Delta "T" Systems' new head vent system uses a single powerful blower to extract air from multiple heads on a vessel. The entire head vent system including the blower, the control unit and the dampers are housed within a central, remotely-located plenum box measuring 16 inches by 12 inches by 13 inches. A single head vent unit is capable of ventilating up to four heads. The system is fully automatic and requires no input from the user. Each head is fitted with a motion detector. When a person enters one of the heads, the system automatically initiates the flow of air from that head. The head vent system is also available in a manual version. The system runs on 24 volts DC and requires only one exhaust port through to the outside of the vessel.

www.deltasystems.com



New Integrated Shaft Coupling Design

VULKAN Couplings introduced a combination of the proven RATO DS coupling with a directly connected Composite shaft. The high radial stiffness and the comparably low axial and bending stiffness makes the RATO DS suitable to work not only as a torsional coupling but also as an integrated misalignment coupling when rigidly connected to an intermediate shaft. At the rear end of the intermediate shaft a torsionally stiff misalignment coupling creates the second bending flexible pivot thus providing a double cardanic design. This new combination consisting of RATO DS and intermediate shaft is called VULKAN Integrated Shaft Coupling (ISC).

www.vulkan.com



DIRECTORY: SHIP & BOATYARDS

Alaska Ship & Drydock, Inc.

3801 Tongass Ave.
Ketchikan, AK 99901
www.akship.com
Doug Ward
tel: 907-228-5302
fax: 907-247-7200
email: info@akship.com
Descr: Full service ship building & repair
Products: Drydocking up to 10,000 long tons, 450 ft LOA; New ship construction

All American Marine

200 Harris Ave.
Bellingham, WA 98225
www.allamericanmarine.com
Joe Hudspeth
tel: 360-647-7602
fax: 360-647-7607
email: jhudspeth@allamericanmarine.com
Descr: Builder of Teknicraft catamarans
Products: High speed passenger vessels, ferries, research vessels, work boats

Atlantic Marine

8500 Heckscher Dr.
Jacksonville, FL 32226
www.atlanticmarine.com
tel: 904-251-3111
email: jaxresumes@atlanticmarine.com
Descr: Shipyard, Florida & Alabama
Products: Ship repair, conversion, shipbuilding

Austal

P.O. Box 1049
Mobile, AL 36633
www.austal.com
Dan Spiegel
tel: 251-434-8000
fax: 251-434-8001
email: sales@austal.com
Descr: Austal's U.S. facility, located in Mobile, Ala. has built and delivered eight vessels since it opened in 2001 and currently employs over 700 shipyard staff
Products: Austal designs and manufactures high-speed aluminum vessels for the commercial & military market

BAE Systems Ship Repair

750 West Berkley Ave.
Norfolk, VA 23523
www.baesystems.com/ShipRepair
tel: 301-838-6000
Descr: BAE Systems Ship Repair is the largest U.S. provider of non-nuclear ship repair, maintenance and modernization. With four repair facilities located on both coasts of the U.S. and in Hawaii, we are ready for any job big or small

Bayonne Dry Dock & Repair Corp.

P.O. Box 240
Bayonne, NJ 07002
www.BayonneDryDock.com
Michael Cranston
tel: 201-823-9295
fax: 201-823-9298
email: info@bayonnedrydock.com

Descr: Covering all areas of ship repair

Bollinger Shipyards, Inc.

P. O. Box 250
Lockport, LA 70374
www.bollingershipyards.com
Robert A. Socha
tel: 985-532-2554
fax: 985-532-7225
email: sales@bollingershipyards.com
Descr: Shipbuilding & repair

Bradford Marine Bahamas

PO Box F-44867
Freeport, GB
Bahamas
www.bradford-grand-bahama.com
Dan Romence
tel: 242-352-7711
fax: 242-352-7695
email: dan@bradford-grand-bahama.com
Descr: Marine repair & construction facility
Products: Yacht & ship repair, barge construction, towing, brokerage

Brunswick Commercial and Government Products

420 Megan Z Ave.
Edgewater, FL 32132
www.brunswickcgp.com
Jeremy Davis
tel: 386-423-2900
fax: 386-423-9187
email: bcgpinfo@whaler.com
Descr: Fiberglass, aluminum and RHIB watercraft for commercial and government applications
Products: Boston Whaler fiberglass boats, impact rigid inflatable boats, Sentry aluminum boats

C & C Boat Works LLC

2617 Engineers Rd.
Belle Chasse, LA 40059
www.ccmrepair.com
Anthony Cibilich
tel: 504-433-4350
fax: 504-433-2383
email: cmtony@bellsouth.net
Descr: New construction
Products: Offshore supply vessels, deck & tank barges

Canal Boats, Inc.

1850 SE 17th St.
Fort Lauderdale, FL 33316
www.watertaxi.com/canalboats
Bob Bekoff
tel: 954-471-7538
fax: 954-728-8417
email: rbekoff@watertaxi.com
Descr: Builders of USCG certified vessels
Products: Water taxis, low wake ferries, excursion & glass bottom boats

Campbell Transportation Co. / C & C Marine Maint.

P.O. Box 124

Charleroi, PA 15022
www.barges.us
William Slite
tel: 724-483-6556
fax: 724-483-6562
email: doreen@ctctowing.com
Descr: Full service repair facilities & floating dry-dock
Products: Dry cargo/liquid barge repair & cleaning operations

CMS North America, Inc.

4095 Karona Ct.
Caledonia, MI 49316
www.cmsna.com
Steve Hillis
tel: 616-698-9970
fax: 616-698-9730
email: cmssales@cmsna.com
Descr: Manufacturer of high-performance, large envelope, five-axis CNC machining centers for boat molds & fabrication of composites/aluminum

Conrad Industries

1501 Front St.
Morgan City, LA 70381
www.conradindustries.com
Gary Lipely
tel: 985-384-3060
email: GBLipely@conradindustries.com
Descr: Conrad builds and repairs tugs, barges, lift-boats, offshore supply vessels, & ferries in steel & aluminum for the commercial and government markets at our four shipyards.

Cutting Edge Metal Processing

363 South Royal St.
Mobile, AL 36603
www.cuttingedgemetal.com
Sam Tanner
tel: 251-431-6922
fax: 251-431-6970
email: metalman@cuttingedgemetal.com
Descr: Advanced technology in metal cutting, forming & coating
Products: Steel processing

Halifax Shipyard and Shelburne Ship Repair

3099 Barrington St.
Halifax, NS B3K 5M7
Canada
www.irvingshipbuilding.com
Donald Kerr
tel: 902-440-5630
fax: 902-492-5818
email: kerr.donald@halifaxshipyard.com
Descr: Ship repair, conversion, new building

Horizon Shipbuilding, Inc.

13980 Shell Belt Rd
Bayou La Batre, AL 36509
www.horizonshipbuilding.com
Travis R. Short
tel: 251-824-1660 ext 222
fax: 251-824-1664
email: trshort@horizonshipbuilding.com
Descr: Shipbuilding & repair



SNAME

ANNUAL MEETING & EXPO

WHERE INDUSTRY & TECHNOLOGY MEET

2011

2011 ANNUAL MEETING CALL FOR PAPERS

NOVEMBER 16 – 18, 2011, HOUSTON , TEXAS

PAPERS ARE WELCOME WHICH AIM TO ADVANCE THE ART, SCIENCE, AND PRACTICE OF:

- NAVAL ARCHITECTURE AND MARINE ENGINEERING
- SHIP CONSTRUCTION AND OPERATION
- OCEAN ENGINEERING
- OFFSHORE TECHNOLOGY
- AND OTHER MARINE-RELATED FIELDS

OTHER GENERAL AREAS OF INTEREST INCLUDE:

- ENVIRONMENTAL CONSIDERATIONS
- HUMAN FACTORS
- LIFECYCLE ENGINEERING
- MARINE ECONOMICS
- MATERIAL TECHNOLOGY
- PIPELINES AND RISERS
- REGULATORY ISSUES
- RENEWABLE OCEAN ENERGY
- SAFETY AND STABILITY
- STRUCTURES AND HYDRODYNAMICS
- SUBSEA TECHNOLOGY
- TRANSPORTATION SYSTEMS

SNAME ANNUAL MEETING & EXPO
EXTENDED ABSTRACTS DUE: MARCH 15, 2011
ABSTRACTS ACCEPTED: MARCH 16, 2011
SUBMIT TO: AM2011@SNAME.ORG

SHIP PRODUCTION SYMPOSIUM
EXTENDED ABSTRACTS DUE: MARCH 1, 2011
ABSTRACTS ACCEPTED: JUNE 1, 2011
SUBMIT TO: SPSPAPERS@SNAME.ORG



WWW.SNAME.ORG

DIRECTORY: SHIP & BOATYARDS

Products: Boats, crewboats, towboats, barges, supply vessels, tugs, repair, conversions, government vessels

Houston Ship Repair, Inc.

16201 Wood Dr.
Channel View, TX 77530
www.houstonshiprepair.com
N.V.R. Sarma
tel: 281-452-5841
fax: 281-452-1087
email: nvrsarma@houstonshiprepair.com
Descr: Topside ship repair & conversion, rig repair & conversion
Products: Authorized Repairers for Jowa Ab oil content monitors & Tsuji Cranes

Intercept Boats

835 Plain St.
Marshfield, MA 02050
www.interceptboats.com
Robert Perette
tel: 781-834-2628
fax: 781-834-2626
email: interceptboats@aol.com
Descr: Boat manufacturing & repair
Products: Special ops craft, interceptors, cargo protection vessels

Ironhead Marine Inc.

2245 Front St.
Toledo, OH 43605
www.ironheadfab.com
Tony LaMantia
tel: 419-690-0000
email: tony@ironheadfab.com
Descr: Full service marine maintenance & repairs, construction, conversion & repowering
Products: Fabrication of furnaces, stacks, conveyors & tanks with two dry docks

MetalCraft Marine Inc.

347 Wellington St.
Kingston, on K7K 6N7
Canada
www.metalcraftmarine.com
Emily Roantree
tel: 613-542-1810
fax: 613-542-6515
email: emily.r@metalcraftmarine.com
Descr: Builders of high-speed aluminum patrol, fire/rescue & work boats

Midship Marine, Inc.

1029 Destrehan Ave.
Harvey, LA 70058
www.midshipmarine.net
Randy Hinojosa
tel: 504-341-4359
fax: 504-340-8997
email: midboats@aol.com
Descr: Aluminum vessel construction
Products: Aluminum passenger ferries, crew/utility vessels, catamarans, semisubmersibles

Mount Royal /Walsh Inc.

2101 Aird Ave.

Montreal, QC H1T3W8
Canada
www.mrw-group.com
Wayne Hynes
tel: 514-255-3301
fax: 514-255-8851
email: mrw@mrw-group.com
Descr: Ship repair

Patti Shipyard, Inc.

306 South Pinewood Ln.
Pensacola, FL 32507
www.pattibuilt.com
Frank Patti Jr. / Ashley Stone
tel: 850-453-1282
fax: 850-453-8835
email: frankjr@pattibuilt.com
Descr: New construction
Products: Tugboats, offshore vessels, inland towboats, passenger vessels

SeaArk Marine, Inc.

P.O. Box 210
Monticello, AR 71657
www.seaark.com
Ken McFalls, VP of Sales
tel: 870-367-9755
fax: 870-367-2120
email: sales@seaark.com
Descr: All welded aluminum boat manufacturer
Products: Boats 17 ft to 65 ft

Signal International, Inc.

905 Pier Rd.
Orange, TX 77630
www.signalint.com
Rob Busby
tel: 281-899-2122
email: rbusby@signalint.com
Descr: A leading Gulf of Mexico provider of marine and fabrication services, including: new construction, heavy fabrication, and offshore drilling rig, ship overhaul, repair, upgrade and conversion
Products: New construction of barges in continuous flow manufacturing facility with automated panel line; fabrication area 450,000 sq ft covered & 20 acres outside, automated wheelabrator

Signet Shipbuilding & Repair

3802 Port River Rd.
Pascagoula, MS 39567
www.signetmaritime.com
Joe Dahl
tel: 251-544-2627
email: Joe.Dahl@SignetMaritime.com
Descr: A full service yard specializing in the new construction, repair, refurbishment and maintenance of tugs, workboats and barges
Products: New construction, repair, topside work of tugs, workboats and barges up to 160 ft; Travelift-600 metric ton, fabrication, waterblasting and painting

Theriault International Ltd

Suite 114, 9049 Commercial St.
New Minas, N.S. B4N 5A4
Canada
www.theriaultinternational.com

C. Theriault
tel: 902-467-0239
fax: 902-467-0326
email: sales@theriaultinternational.com
Products: New builds, repairs, conversions, deck equipment, liferafts, wipers (rags), chandlery, etc.

Todd Pacific Shipyard

1801 16th Ave. SW
Seattle, WA 98134
www.toddpacific.com
Martin J Muniz
tel: 206-623-1635 ext 110
fax: 206-442-8512
email: marty.muniz@toddpacific.com
Descr: Ship building / ship repair

Yarde Metals

45 Newell St.
Southington, CT 06489
www.yarde.com
Rick Marcinczyk
tel: 860-406-6061
fax: 860-406-6040
email: sales@yardem.com
Descr: Yarde Metals carries extensive inventory of marine grade aluminum alloys in 5083 & 5086; The 5000 series is stocked in ASTM B 928 specification; Stocked in extra wide sheet and plate; Aluminum alloys are also available in 6000 series
Products: Aluminum, stainless, carbon steel, brass & cooper

Zito Companies

P.O. Box 10306
Jefferson, LA 70181
www.a-zito.com
Jack Wershbaile
tel: 504-835-8531
fax: 504-833-3116
email: jack@a-zito.com
Descr: Marine repair & fabrication

BY THE NUMBERS

Offshore Rig Fleet by Region

Region	%	No.
Africa – West	83.3%	(50/60)
Asia – SouthEast	69.8%	(67/96)
Europe - North Sea	86.7%	(65/75)
Mediterranean	66.7%	(14/21)
MidEast - Persian Gulf	73.4%	(69/94)
N. America – Mexico	74.2%	(23/31)
N. America - US GOM	79.2%	(61/77)
S. America – Brazil	86.4%	(57/66)

Source: Rigzone

Offshore Rig Utilization by Type

Type	%	No.
Drill Barge	80.0%	(8/10)
Drillship	70.0%	(42/60)
Jackup	76.4%	(278/364)
Semisub	81.7%	(143/175)
Tender	73.3%	(22/30)

Source: Rigzone

Offshore Rig Day Rates

Floating Rigs

Rig Type	Rigs Working	Total Rig Fleet	Average Day Rate
Drillship < 4000' WD	4 rigs	8 rigs	\$241,200.00
Drillship 4000'+ WD	41 rigs	54 rigs	\$464,495.64
Semisub < 1500' WD	9 rigs	18 rigs	\$251,493.75
Semisub 1500'+ WD	65 rigs	87 rigs	\$298,261.94
Semisub 4000'+ WD	80 rigs	100 rigs	\$413,787.50

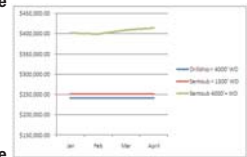

Jackup Rigs

Rig Type	Rigs Working	Total Rig Fleet	Average Day Rate
Jackup IC < 250' WD	31 rigs	53 rigs	\$75,500.00
Jackup IC 250' WD	38 rigs	64 rigs	\$90,732.26
Jackup IC 300' WD	88 rigs	126 rigs	\$96,387.25
Jackup IC 300'+ WD	116 rigs	152 rigs	\$134,916.24
Jackup IS < 250' WD	5 rigs	7 rigs	—
Jackup IS 250' WD	8 rigs	10 rigs	\$137,000.00
Jackup IS 300' WD	2 rigs	5 rigs	\$60,300.00
Jackup IS 300'+ WD	1 rigs	3 rigs	\$55,000.00
Jackup MC < 200' WD	3 rigs	12 rigs	\$34,333.33
Jackup MC 200'+ WD	13 rigs	28 rigs	\$46,885.42
Jackup MS < 200' WD	2 rigs	2 rigs	—
Jackup MS 200'+ WD	6 rigs	19 rigs	\$72,950.00

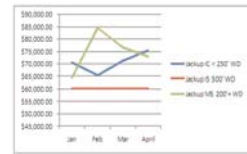

Other Offshore Rigs

Rig Type	Rigs Working	Total Rig Fleet	Average Day Rate
Drill Barge < 150' WD	18 rigs	39 rigs	—
Drill Barge 150'+ WD	6 rigs	9 rigs	—
Inland Barge	27 rigs	75 rigs	\$56,620.00
Platform Rig	144 rigs	250 rigs	\$42,516.50
Submersible	0 rigs	6 rigs	—
Tender	22 rigs	32 rigs	\$129,710.00

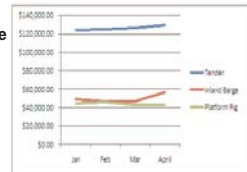

Source: Rigzone

Source: Charts courtesy of Waterborne Commerce Statistics Center, New Orleans, La. (<http://www.iwr.usace.army.mil/ndc/wcsc/wcsc.htm>)

TSA Surcharge

West Coast

Date	\$/MT	ch/\$	ch/%
May 23	642.00	-11.00	-1.7
May 16	653.00	-12.50	-1.9
May 9	665.50	-23.50	-3.4
May 2	689.00	-2.00	-0.3
Apr 25	691.00	-1.50	-0.2
Apr 18	692.50	-9.50	-1.4
Apr 11	702.00	+3.50	+0.5
Apr 4	698.50	+31.50	+4.7
Mar 28	667.00	+16.00	+2.5
Mar 21	651.00	+0.50	+0.1
Mar 14	650.50	-6.50	-1.0
Mar 7	657.00	+8.00	+1.2

East Coast

Date	\$/MT	ch/\$	ch/%
May 23	637.00	-3.00	-0.5
May 16	640.00	-17.00	-2.6
May 9	657.00	-32.00	-4.6
May 2	689.00	+1.00	+0.1
Apr 25	688.00	+2.50	+0.4
Apr 18	685.50	-10.00	-1.4
Apr 11	695.50	+16.50	+2.4
Apr 4	679.00	+26.50	+4.1
Mar 28	652.50	+8.50	+1.3
Mar 21	644.00	-15.00	-2.3
Mar 14	659.00	+4.00	+0.6
Mar 7	655.00	+8.50	+1.3

Source: Bunkerworld.com

<http://www.bunkerworld.com/markets/surcharges/tsa#>

Indicative World Steel Prices

Indicative prices		Change
SBB HRC world price \$/t	807.401	-4
SBB Rebar world price \$/t	738.57	+12
SBB World Price Tracker	279.099	-5

Source: Steel Business Briefing

<http://www.steelbb.com/steelprices/>

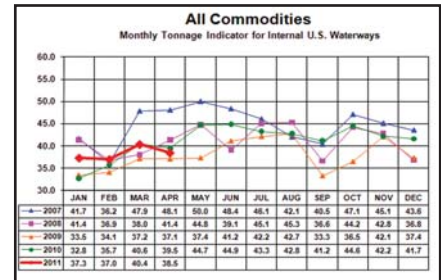
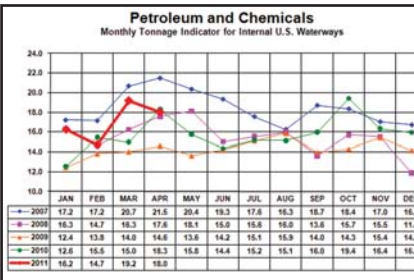
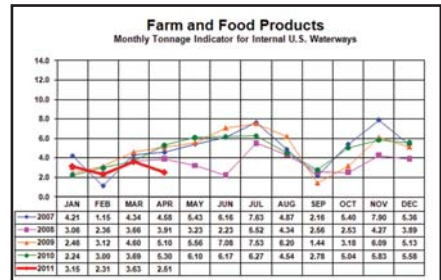
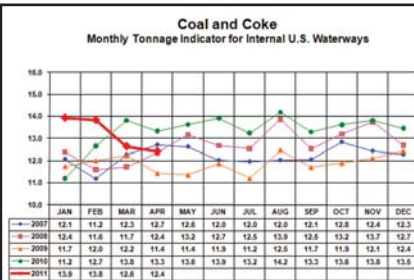

Bunker Fuel

Port	IFO 380	IFO 180	MGO	Del. Date
Corpus Christi	665.00	695.00	995.00	W 2011-05-27
Houston	625.00	655.00	940.00	W 2011-05-27

Source: BunkerIndex.com - <http://www.bunkerworld.com/markets/prices>

Port	IFO380	IFO180	MGO	MDO	Barge	Updated
New York	657.50	691.00	—	1021.00	\$7.50	May 27
Houston	634.00	676.00	—	972.50	\$7.00	May 30
Los Angeles	637.00	667.00	—	1018.00	\$5.80	May 30

Source: Bunkerworld.com - <http://www.bunkerworld.com/markets/surcharges/tsa#>

Post Your Resume for Free • Energize Your Job Search @ MaritimeJobs.com

BAE SYSTEMS

Job Posting Title: Commercial Sales Manager - East Coast Ship Repair
Job Location: Arlington, VA
Job Posting Number: 361419

BAE Systems is a premier global defense and security company with approximately 100,000 employees delivering a full range of products and services for air, land and naval forces, as well as advanced electronics, security, information technology solutions and customer support and services.

DESCRIPTION

Market BAE Commercial & non USN Government Ship Repair and conversion capabilities in the US Northeast and East Coast.

- Responsibility for following markets MSC (GOGO vessels), MSC operator (GOCO vessels), Commercial East Coast, USCG/MARAD /USACE

This position provides mid-grade level BAE Systems Sales Manager support focused on the development, capture plans, marketing and management Commercial Sector and non-USN Government maritime new construction and repair opportunities, resulting in winning, implementing and executing new construction contracts leveraging BAE Systems Ship Repair capabilities and shipyard capacity. The initial focus will be the exploration and selection of critical market segments and assisting the individual yards with investment plans and business case analysis to further improve BAE Systems competitive position in these market segments. This Maritime (commercial and Other Government) Sales Manager will be responsible for interfacing with the appropriate shipyard leadership, Customer Representatives, BAE Systems Corporate leadership and Senior Stakeholders to win business, assist in the development and execution of commercial and other Government strategies to align with BAE Systems strategic planning leading to maritime domain growth.

This Sales Manager will understand and leverage the customer's vision, budgeting and planning activities to best meet growth targets in the commercial and other government sectors. This Sales Manager will be responsible for interfacing internally within BAE Systems Ship Repair at the appropriate level to gain sufficient insight and buy-in for development and execution of a BAE Systems Maritime Strategies, business alignment and contract execution plan. This Sales Manager will be responsible to work across the enterprise to assist in the identification the additional capabilities and resources required to execute the BAE Systems Maritime strategy as it applies to the commercial and other government business sectors.

ADDITIONAL REQUIREMENTS

Education:

Bachelors Degree in a related field

Required experience:

8-10 years of experience in a related field

Primary Roles and Responsibilities:

- Identify and develop BAE repair capabilities to the Commercial & non USN Government market.
- Develop and implement a market account plan for specific customers with the market domain.
- Conduct customer visits and performs research to understand current and emerging customer needs, requirements and repair and conversion market trends.
- Establish build and maintain customer relationships and assesses competitor capabilities.
- Research strategic partnerships.
- Develop and execute strategic and tactical plans, both short and long range for the pursuit and successful capture of key opportunities.
- Lead the development and evaluation of the technical and management content and contractual compliance of proposals.
- Provide management with information to identify critical areas of the opportunity's win strategy to minimize risk and maximize the profitability of win.
- Participate in bid decisions, the development of cost strategies and phase reviews.

NOTE: This position may require up to 50% travel.

CLOSING

People are the greatest asset in any Company ...

BAE Systems is committed to a high performance culture and provides an environment that challenges our employees to be remarkable and obtain their full potential.

We are an EEO/Affirmative Action Employer that understands the value of diversity and its impact on a high performance culture.

Join us ...

HOW TO APPLY:

To apply to this position, please visit our website at <http://www.baesystems.jobs> and reference requisition number 361419.

The direct link to the position is:

http://www.baesystems.jobs/job_detail.asp?JobID=1792503

BAE SYSTEMS

Job Posting Title: Commercial Sales Manager - New Vessel Construction
Job Location: Arlington, VA
Job Posting Number: 361417

BAE Systems is a premier global defense and security company with approximately 100,000 employees delivering a full range of products and services for air, land and naval forces, as well as advanced electronics, security, information technology solutions and customer support and services.

DESCRIPTION

This position provides mid-grade level BAE Systems Sales Manager focused on the development, capture plans, marketing and management Commercial Sector and non-USN Government maritime new construction and repair opportunities, resulting in winning, implementing and executing new construction contracts leveraging BAE Systems Ship Repair capabilities and shipyard capacity. The initial focus will be the exploration and selection of critical market segments and assisting the individual yards with investment plans and business case analyses to further improve BAE Systems competitive position in these market segments. This Maritime (commercial and Other Government) Sales Manager will be responsible for interfacing with the appropriate shipyard leadership, Customer Representatives, BAE Systems Corporate leadership and Senior Stakeholders to win business, assist in the development and execution of commercial and other Government strategies to align with BAE Systems strategic planning leading to maritime domain growth. This Sales Manager will understand and leverage the customer's vision, budgeting and planning activities to best meet growth targets in the commercial and other government sectors. This Sales Manager will be responsible for interfacing internally within BAE Systems Ship Repair at the appropriate level to gain sufficient insight and buy-in for development and execution of a BAE Systems Maritime Strategies, business alignment and contract execution plan. This Sales Manager will be responsible to work across the enterprise to assist in the identification the additional capabilities and resources required to execute the BAE Systems Maritime strategy as it applies to the commercial and other government business sectors.

ADDITIONAL REQUIREMENTS

Education:

Bachelors Degree in a related field

Required experience:

8-10 years of experience in a related field

Primary Roles and Responsibilities:

- Identify and develop BAE repair capabilities to the Commercial & non USN Government market.
- Develop and implement a market account plan for specific customers with the market domain.
- Conduct customer visits and performs research to understand current and emerging customer needs, requirements and repair and conversion market trends.
- Establish build and maintain customer relationships and assesses competitor capabilities.
- Research strategic partnerships.
- Develop and execute strategic and tactical plans, both short and long range for the pursuit and successful capture of key opportunities.
- Lead the development and evaluation of the technical and management content and contractual compliance of proposals.
- Provide management with information to identify critical areas of the opportunity's win strategy to minimize risk and maximize the profitability of win.
- Participate in bid decisions, the development of cost strategies and phase reviews

NOTE: This position may require up to 50% travel.

CLOSING

People are the greatest asset in any Company ...

BAE Systems is committed to a high performance culture and provides an environment that challenges our employees to be remarkable and obtain their full potential.

We are an EEO/Affirmative Action Employer that understands the value of diversity and its impact on a high performance culture.

Join us ...

HOW TO APPLY:

To apply to this position, please visit our website at <http://www.baesystems.jobs> and reference requisition number 361417.

The direct link to the position is:

http://www.baesystems.jobs/job_detail.asp?JobID=1792501

Equipment Technical Marketing Manager

Job Location: USA, Whippany, NJ

The equipment technical marketing manager will leverage their engineering and traditional product management skills for marine equipment inclusive of metering and dosing systems globally.

The position will support five product lines engaged in marine applications in fuel management, water treatment, maintenance, welding, and refrigeration. The role is engineering focused with the responsibility for planning and stewardship of assigned products throughout the product lifecycle.

The technical marketing manager will lead cross-functional teams to integrate systems and processes to achieve project deliverables. Other key responsibilities include:

- Generate budgeted equipment sales volumes globally for equipment portfolio
- Manage supplier relationships and instruct operations on business requirements
- Configure equipment proposals and communicate special requirements to suppliers
- Develop product collateral, including product data sheets, sales presentations, and demonstration kits or apparatus

Requirements:

Bachelor of Science (BS) or equivalent in mechanical or marine engineering; a Master of Science or Master of Business Administration is preferred 5+ years in a technical role or industrial marketing experience, preferably in the Maritime Industry Understanding of IMO, classification and flag administration rules a plus Up to 25% travel, Domestic & International

Please send resume to hr@drewmarine.com. All submissions should include the position title in the email subject.

Company Profile:

Drew Marine is a recognized leader in providing technical solutions and services to the Global Marine Industry. Drew Marine leads the industry in innovative technology, responsive delivery, and cost-effective solutions to unique marine

Post Your Resume for Free • Energize Your Job Search @ MaritimeJobs.com

MaritimeJobs.com

where employers and job seekers connect

The Maritime Industry's Leading Employment Website. For more information contact: Jean Vertucci at vertucci@marinelink.com

challenges. With over 81 years of business, Drew Marine provides exceptional value, with products and services that help our customers achieve operational efficiency and regulatory compliance when and where needed. Drew Marine is a privately owned global company servicing the maritime industry.

Please send resume to hr@drew-marine.com. All submissions should include the position title in the email subject.

Human Resources
Drew Marine
NJ USA
Email: hr@drew-marine.com

THE VANE BROTHERS COMPANY

NEW YORK ★ PHILADELPHIA ★ BALTIMORE ★ NORFOLK ★ CHARLESTON



On Course For the Future

The Vane Brothers Company is recruiting qualified candidates for positions on our state-of-the-art marine transport vessels operating along the Atlantic Seaboard.

Tug Masters and Mates, Marine Engineers and Tankermen opportunities are available.

Learn more at www.vanebrothers.com or contact fleet recruitment at 410-735-8212.



**HIRING FOR ALL
POSITIONS
CAPTAINS-MATES-PILOTS-
DP OPER.**

**ENGINEERS-DDE(ANY)-
CHIEF (OSV-LIMITED-
UNLIMITED) UNLIC W EXP.**

**QMED-OILER-PIC-AB
(ANY RATING)**

**OS-CRANE OPER-COOK-
D/Hs**

Email resumes to
info@boatjobs.co

251-665-7125

www.boatjobs.co

MASSACHUSETTS MARITIME ACADEMY

Founded in 1891, the Massachusetts Maritime Academy is the nation's oldest and finest co-ed maritime college. The Academy prepares young women and men for exciting and rewarding careers on land and sea. Our graduates have been at the very top of seagoing, engineering, environmental, and international business professions.

POSITIONS AVAILABLE

International Maritime Business Faculty
Staff Assistant Third Assistant Engineer
Maintainer II

The Academy is located in Buzzards Bay at the mouth of the scenic Cape Cod Canal and is a special mission college within the Massachusetts university college system.

For information about this positions and how to apply, visit the employment quick link on our web page at www.maritime.edu.

Massachusetts Maritime Academy is an AA/EEO employer. Under-represented groups are encouraged to apply.



Professional Mariner Directory

- ★ Advanced Mariner Search
- ★ Post Maritime Job Listings
- ★ Accept Applications

www.FindAMariner.com

Find Crew Today

General Manager NOLA Shipyard

Well Established Shipyard Repair Operation now seeking a maritime specialist to head up a medium sized shipyard/repair facility in the New Orleans area. Candidates must have at least five years of experience in front line management and will be responsible for the day to day operations, production, estimating, billing and customer relationship building. We offer Competitive wages, Comprehensive Medical/Dental program, Company Match 401 (k) program, Paid Vacations and Holidays. We are an Equal Opportunity Employer.

Confidential resumes may be submitted to:

maritimeportjobs@yahoo.com

P.O. Box 3157 • Paducah, KY 42002-3157

Vessels for Sale



www.geoshipyard.com

4817 South Lewis St.
PO BOX 9622
New Iberia, LA 70586-9622

Phone: (337) 367-1541
Fax: (337) 364-7493

- Survey Boats**
- Patrol Boats**
- Crew/Supply Boats**
- Pilot Boats**
- Passenger Ferries**
- Seismic Boats**
- Push/Tug Boats**

Building superb vessels since 1979

Email: david@geoshipyard.com

RASMUSSEN EQUIPMENT COMPANY

Used Vertical Warping Capstans



MODEL SA1817-22H
18" Barrel, 22 hp, 1300 PSI/30 GPM, Sacrificial steel doubler plates.
Location: Seattle, WA
Price: \$30,000 ea., As Is

Tel: 206-762-3700 • www.rasmussenco.com
Fax: 206-762-5003
We've been serving the general & marine construction industries for over 70 years.

Southern Recycling 

We buy barges, ships, and other marine vessels and structures for scrap.
We adhere to the highest ES&H standards.
Serving the rivers and coasts of the U.S.

MOBILE • MORGAN CITY • NEW ORLEANS
• AMELIA • HOUSTON
CALL 800 - GO SCRAP

Not just another social networking site!



30,000+ unique users
9,000+ members
87,000+ page views

Maritime Professional is a dynamic online business resource, created to serve companies, researchers, and innovators worldwide. We draw high-level members with industry-specific contact networks, discussion forums, seminars, and blogs. Unlike broad-based networking sites which try to be "something to everyone," Maritime Professional is specifically focused on the growing global network of marine researchers, professionals and executives.

Each member profile is self-created and maintained using real names and contact information, giving your company direct access and exposure to thousands of legitimate decision making professionals.

Maritime Professional is dedicated to making and maintaining crucial maritime industry connections.

Featuring:

- News
- Blogs
- Groups
- Forums
- Groups

Brought to you by the leading news source for the global maritime industry, Maritime Reporter & Engineering News.

JOIN TODAY!

MaritimeProfessional.com
the maritime industry online

MARINE BUSINESS EXCHANGE

Mergers, Acquisitions & Divestitures

www.marinebusinessexchange.com

Are you ready to sell your business or are you ready to expand your business through a merger or acquisition? We presently have investors who are seriously interested in all types of marine and marine related companies worldwide.

9786 Timber Circle, Suite A
Daphne, AL 36527
Ph: 251-626-0713
Cell: 504-650-5000
Fax: 251-447-0423
E-mail: info@marinebux.com



Marine Marketplace

US Coast Guard Approved (STCW-95) Basic Safety Training

- Basic Safety Training
- Medical PIC
- Proficiency in Survival Craft
- Tankerman PIC
- Advance Firefighter
- Vessel Security Officer

El Camino College
Workplace Learning Resource Center
13430 Hawthorne Blvd. • Hawthorne, CA 90250
Ten (10) minutes from LAX • Twenty (20) minutes from LA Harbor
Call for Information & Registration
(310) 973-3171/47 • www.businessassist.org/wplrc/coast.html

The industry's premier online news source

MarineLink.com

- contracts
- offshore
- security
- company news



RASMUSSEN EQUIPMENT COMPANY



Berger Fairleads • Anchor • Spud Winches • Skagit Clyde • Manitowoc • Deck Winches

(800) 227-7920 • equipmentsales@rasmussenco.com

Standard rental/sale terms and conditions may be viewed on the homepage at our website, www.rasmussenco.com

Marine Marketplace

NEW PRODUCTS

PORTABLE DIESEL EMERGENCY PUMP



DIESEL AMERICA WEST with over 25 years of experience offers a QUALITY ocean service, emergency de-watering - transfer - trash pump that is portable rugged - & light weight.

- 304 Stainless Steel Frame (1" welded sq. tube)
- Heavy Duty "Non-Metallic" Trash Pump End
- Seal is Severe Service s/Steel & Viton Shaft Seal
- YANMAR 5 & 7 H.P. Diesels, Aircooled
- 2" x 2" or 3" x 3" N.P.T. • 42 P.S.I. Max
- Heavy Duty Vibration Isolators
- Long Life Marine Components Throughout

A Serious, Portable, Saltwater Service Emergency Pump

Diesel America West Inc.
P.O. Box 968, Friday Harbor, WA 98250
Phone (800) 343-7351 or (360) 378-4182
Fax (360) 378-3315 (24hr line)
www.dawest.com

WHEN YOU NEED LONGEVITY, YOU NEED WING.

At Wing, we take pride in our design, construction and quality. That's why we are the provider of choice for replacement sponsons by agencies around the world. Some of our more than 200 existing replacement sponsons designs include:



Contact Wing for a complete listing of existing replacements or for a custom replacement quote.

U.S.C.G. Replacements

Zodiac 540™
Zodiac 630™
Zodiac 640™
Zodiac 733™

S.O.L.A.S. Replacements

Willard 670™
Zodiac 670™

Military Replacements

BCGP Impacts™
Moose Boats™
SeaArk™
US Marine Inc. 11m Split Bow™
Willard 730™
Willard 11m™
Zodiac™

Commercial Replacements

Almar™
North River™
Northwind™
Zodiac™

WING
INFLATABLES

Designed Smarter. Built Tougher.

1220 5th Street • Arcata, California, 95521 Phone: 707.826.2887 • www.wing.com

Cooley

Wing uses fabric coated with Coolthane®—an advanced polyurethane coating manufactured by Cooley, 50 Esten Avenue, Pawtucket, RI 02860 • 1-800-333-3048 • www.cooleygroup.com

BOOKS FOR THE SHIPPING INDUSTRY

www.nauticalmind.com



The Nautical Mind Bookstore
email: books@nauticalmind.com
toll free: (800) 463-9951

ATLASS INSURANCE
QUOTE LINE: 800-330-3370

TUGS | BARGES | RIGS | CREW
SIGHTSEEING | WORK & SUPPLY BOATS

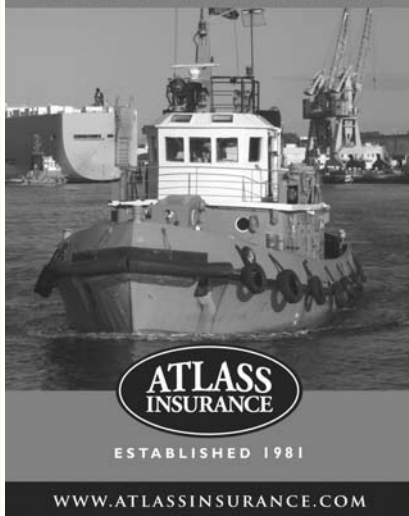

ATLASS
INSURANCE

ESTABLISHED 1981

WWW.ATLASSINSURANCE.COM

USCG

License Software

Affordable - Merchant Marine Exam Training

<http://hawsepipe.net>

Freelance Software
39 Peckham Place
Bristol, RI 02809

(401) 556-1955 - sales@hawsepipe.net

MANDEL
METALS

ALUMINUM USA



MARINE ALUMINUM

SHEET, COIL, PLATE

5052/5454/5083/5086

H116/H321/ABS/ASTM B928

20 MILLION POUND INVENTORY

NATIONWIDE DELIVERY

1-877-752-5052

FAX: 214-905-3900

E-MAIL: jayson@mandelmetals.com

WEB: www.mandelmetals.com

REMOVE
paint, rust, scale & barnacles
from hard surfaces



DESIMONID
800.823.4670 www.swirloff.com

Marine Marketplace

NEW PRODUCTS

Many Styles Available

100% Glare Reduction
5 Mils thick

Bunk Curtains

Mylar Sun Screens

Fire-Retardant
IMO Certified

Porthole Curtains

IMMEDIATE DELIVERY on selected styles
(718) 983-5600 (800) 336-6857 Fax (718) 983-9127
Website: metromarine.com E-mail: sales@metromarine.com
METRO MARINE DESIGN ASSOCIATES MADE IN THE USA

PORTABLE DIESEL FIRE PUMP



DIESEL AMERICA WEST with over 25 years of experience offers a QUALITY ocean service, lightweight, portable diesel fire pump that exceeds U.S.C.G. specifications

- #304 Stainless Steel Frame (1" welded sq. tube)
- Pump End w/Bronze Impeller
- Severe Service s/Steel & Viton Shaft Seal
- YANMAR 7 H.P. Diesel Aircooled Engine
- 2" x 2" N.P.T. • 150 G.P.M. • 90 P.S.I.
- Heavy Duty Vibration Isolators
- Long Life Marine Components Throughout

A Serious, Portable, Saltwater Service Fire Pump

Diesel America West Inc.
P.O. Box 968, Friday Harbor, WA 98250
Phone (800) 343-7351 or (360) 378-4182
Fax (360) 378-3315 (24hr line)
www.dawest.com

MARINE DUTY PORTABLE SURFACE PREP EQUIPMENT



Pressure Washer Systems Up to 7,000 PSI Shipped Worldwide

WATER CANNON
WATERCANNON.COM
1-800-333-WASH(9247)

METAL FABRICATING MACHINERY

**SHEARING-PUNCHING-DISHING
BENDING-ROLLING-FLANGING**

IRONWORKERS

**SECTION BENDING ROLLS
PRESS BRAKES & SHEARS
PLATE BENDING ROLLS**

ALL TYPES, SIZES & CAPACITIES

410-933-8500
sales@comeq.com
WWW.COMEQ.COM

MARITIME PROPULSION

Powering the Maritime Industry

Maritime Propulsion is the online database for marine power and propulsion equipment. Find product reports, engine specifications, suppliers, and auxiliary machinery.

www.maritimepropulsion.com

Anchors
Barges
Compressors
Cranes
Crew Boats
Dredges
Engines/Gears
Ferry Boats
Fishing Vessels
Generators
Landing Craft
Passenger Vessels
Propellers
Ship Parts
Tugs
Winches
Work boats
Yachts/
Pleasure Craft

Scruton Marine Services

Peggy or Mike Scruton
MARINE BROKERS
49 John Street
Port Dover Ontario,
NOA 1N7
Website:
www.scrutonmarine.com
Email:
sms@scrutonmarine.com
Ph: (519) 583-1636
Fax: (519) 583-2189

"SCRUTONIZE YOUR INVENTORY"



Sea water intake filters,
strainers and screens

866 - 265 - 0502

Yankee Wire Cloth Products, Inc.
221 W. Main St.,
West Lafayette OH 43845
Fax: 740-545-6323
www.maritimefilter.com

CORROSION & WALL THICKNESS GAUGE

The TI-25M measures wall & corrosion thickness on all metals, ceramics, glass and most rigid plastics from only one side—ultrasonically!

Measuring Range
0.025 – 6.000 inches
0.60 – 150.0 mm

Five-Year Warranty

• Many other models available including—
THRU PAINT
DATALOGGING
UNDERWATER

Call Toll Free 1-800-645-4330

ELECTROMATIC Equipment Co., Inc.
600 Oakland Ave., Cedarhurst, NY 11516
Tel. (516) 295-4300 • FAX (516) 295-4399
www.checkline.com

CHECKLINE®

TideSlide

Mooring Products & Systems

"Your Berth Control is Our Business!"

1(800)780-6094 +1(989)695-2646 www.TideSlide.com



VB1 Vessel Based TideSlide Systems

- *Free Valuable Deck Space
- *Improve Crew Safety
- *Pier Height Line Positions
- *No Maintenance
- *Moor Any Ship, Any Pier Worldwide
- *Completely Automatic Deployment
- *Safe Sea-State Mooring
- *Increase Mooring Efficiency
- *Integrated Systems or Retrofitted for Any Vessel

VB1 Vessel Based & Pier Based Mooring Systems

Marine Marketplace

PROFESSIONALS

We've Got a Boatload of Experience

Put our 35 years of experience to work on your next offshore exploration, production and marine transportation project.

- Design/Engineering Services
- State-of-the-Art Technology
- Project Management
- Legal/Arbitration
- Negotiations
- Surveys

Alan C. McClure Associates, Inc.

Naval Architects • Engineers

Phone: (713) 789-1840 • www.acma-inc.co/mn

C. R. CUSHING & Co., INC.
NAVAL ARCHITECTS • MARINE ENGINEERS • TRANSPORTATION CONSULTANTS

30 VESEY ST
7TH FLOOR
NEW YORK, NY
10007

1968 **40** 2008
ANNIVERSARY

Ph: (212) 964-1180
Fax: (212) 285-1334
info@crcco.com
www.crcco.com



genoadesign
international Ltd.

“Production Lofting & Detail Design”

Servicing marine and offshore industries internationally.

- Barges • OSVs • Towboats • Tugs
- Ferries • Tankers • Workboats

www.genoadesign.com

**2011 Update
GHS Version 12.50**

Over 50 new features, 15 template enhancements and nine new system variables. Additional support for progressive flooding and flow calculations. Further refinements in probabilistic damage, oil outflow and MODU criteria. Crane modeling with detailed graphics supporting both standard and knuckle booms. Extended handling of open hoppers including sliding and solid cargo with several modes of water over cargo. Well over 100 small improvements that further advance the performance and reliability of this software.

GHS Load Monitor (GLM), the onboard configuration of GHS, gives naval architects the ability to provide their clients the best combination of features including the latest damage stability requirements.



General Hydrostatics

Ship Stability and Strength Software

GHS Full-featured naval architect's system
GHS Load Monitor (GLM) Onboard configuration
GHS/Salvage Salvor's package
BHS Basic hydrostatics and stability

Creative Systems, Inc.
Creators of GHS™

P.O. Box 1910 Port Townsend, WA 98368 USA
phone: (360) 385-6212 fax: 385-6213
email: sales@ghsport.com
www.GHSport.com

For 39 years, the software naval architects love.

Engineering And Design

Marine Casualty Response

Marine Survey And Inspection

Port Engineering Services



JMS
NAVAL ARCHITECTS
SALVAGE ENGINEERS
JMSnet.com • 860.536.0009

New! > 

JMS applications for your iPhone.
U.S. Navy Salvor's Handbook
Go to > www.JMSnet.com



SAMS®

Society of Accredited Marine Surveyors®

An International Organization of Professional Marine Surveyors

For SAMS® surveyors in your area, CALL
1-800-344-9077
<http://www.marinesurvey.org>
4605 Cardinal Blvd. • Jacksonville, Florida 32210

MORRELLI & MELVIN DESIGN & ENGINEERING, INC.

30 Years of Vessel Experience

Workboats, Fast Ferries,
Charter & Support Vessels



www.morrellmelvin.com | info@morrellmelvin.com
4952 Warner Avenue, Suite 205
Huntington Beach, CA 92649
TEL: (714) 861-1320 FAX: (714) 840-0538

Marine Surveyor Course and Training

Standards based training for all vessels.

1-800-245-4425

www.navsurvey.com

Marine News

Classified Sales

- ★ Cost Effective Advertising
- ★ Lower Cost = Higher Frequency
- ★ Higher Frequency = More Visibility
- ★ More Visibility = Higher Sales
- ★ Higher Sales = Happy Advertisers



Marine News has the highest circulation serving the workboat industry giving your Classified Ad the highest exposure at the lowest cost!

www.marinelink.com

BARGES FOR RENT

TUGS/BARGES FOR RENT
BARGES SIZED FROM 8'x18' TO 45'x120' ALSO "SHUGART" SECTIONAL BARGES
"TRUCKABLE TUGS" HERE

Smith Brothers Inc.,
Galesville, MD 20765
(410) 867-1818
www.smithbarge.com

ADVERTISER INDEX

Page#	Advertiser	Website	Phone#	Page#	Advertiser	Website	Phone#
29	ABS	www.eagle.org	(281) 877-5861	C2	KVH	www.kvh.com/V3	(401) 847-3327
5	AER SUPPLY	www.aersupply.com	(800) 767-7606	49	MARINERS HOUSE	www.marinershouse.org	(617) 227-3979
20	AHEAD SANITATION SYSTEMS	www.aheadtank.com	(337) 237-5011	23	McDonough Marine Services	www.mcdonoughmarine.com	(504) 780-8100
41	AMERIC CORPORATION	www.americ.com	(800) 364-4642	33	METAL SHARK ALUMINUM BOATS	www.metalsarkboats.com	(337) 364-0777
41	BREAUX BAY CRAFT	Please call us at	(337) 229-4246	20	NABRICO	www.nabrico-marine.com	(615) 442-1300
31	CHROME CRANKSHAFT	www.chromecrankshaft.com	(815) 725-9030	35	NEW YORK STATE CANAL CORPORATION	www.canals.ny.gov	(518) 471-5349
35	DeFelsko	www.defelsko.com	(315) 393-4450	13	PORT SUPPLY- WEST MARINE	www.portsupply.com	(800) 621-6885
3	Delta Wave Communications , Inc.	www.deltawavecomm.com	(866) 650-9283	C4	R.W. FERNSTRUM & CO. INC.	www.fernstrum.com	(906) 863-5553
33	DONJON MARINE	www.donjon.com	(908) 964-8812	1	SCANIA USA	www.scaniausa.com	(210) 403-0007
39	GENCORP INSURANCE	www.gencorp-ins.com	(800) 232-0582	36-37	SEA TEL	www.cobham.com/seatel	Please visit us online
5,27	GLOBAL MARINE POWER	www.globalmarinepower.com	(713) 640-9300	7	SIGNAL INTERNATIONAL	www.signalinternational.com	(251) 544-2627
25	GLOBAL SATELLITE USA	www.globalsatellite.us	(954) 522-6260	47	SKOOKUM	www.skookumco.com	(800) 547-8211
15	GREAT AMERICAN INSURANCE	www.GreatAmericanOcean.com	(212) 510-0135	55	SNAME	www.sname.org	(561) 732-4368
38	H.O. BOSTROM	www.hobostrom.com	(262) 542-0222	25	STEELWAYS, INC.	www.steelwaysinc.com	(845) 562-0860
43	HARCO MANUFACTURING CO.	www.harcomanufacturing.com	(800) 394-7571	43	SUNY MARITIME COLLEGE	www.sunymaritime.edu	(718) 409-7341
41	HILLIARD CORPORATION	www.hilliardcorp.com	(607) 733-7121	9	TEXTRON MARINE AND LAND SYSTEMS	www.lowriskssc.com	(410) 628-3184
17	INMARSAT	www.inmarsat.com/efficiency	Please visit our website	C3	TUFLEX RUBBER PRODUCTS	www.tuflex.com	(800) 770-6008
11	JAPAN RADIO CO., LTD	www.jrcamerica.com	(206) 654-5644	41	Tutor-Saliba	Please call us at	(818) 362-8391
45	JMS- Naval Architects and Salvage Engineers	www.jmsnet.com	(860) 536-0009	21	WALKER ENGINEERING, USA	sales@walkerairsep.com	(818) 252-7788
15	KEMEL USA INC.	www.kemelusa.com	(212) 967-5575	19	ZF Marine	www.zfmarineparts.com/amn	(877) 896-4040

*The listings above are an editorial service provided for the convenience of our readers.
If you are an advertiser and would like to update or modify any of the above information, please contact: productionmanager@marinelink.com*



GSA

Contract Holder

May contribute to LEED® certification.
Made in the USA.

Insist on Tuflex Rubber Flooring for Your Fleet

- Superior sound dampening
 - Unparalleled durability
- Ease of installation and maintenance
 - Slip resistant and nonporous
 - Cushioned support under foot
- Also proudly offering IMO Certified products



"All our customers appreciate the sound absorption of Tuflex."

- Jim Tubor -

Quality Shipyards
(A Tidewater Company)

"We've used Tuflex for 10 years. We've not had one problem."

- Mike O'Connor -

Surface Systems, Inc.



Tuflex Rubber Products, LLC
Sports & Marine Division
World Trade Center Tampa Bay

1101 Channelside Drive, Suite 244, Tampa, Florida 33602 U.S.A.

T: 800.770.6008 | E: marine@tuflex.com



R.W. FERNSTRUM & COMPANY



FERNSTRUM®
GRIDCOOLER®

FERNSTRUM - WEKA - TRANTER®

R.W. Fernstrum & Company now offers more heat transfer products to the marine industry than ever before. With FERNSTRUM® GRIDCOOLER® keel coolers, Weka Boxcoolers, and TRANTER's Plate & Frame, Platecoil® and Shell & Plate heat exchangers, Fernstrum can provide a cooling solution to meet your needs.



FERNSTRUM®
GRIDCOOLER® KEEL COOLER



TRANTER
The heat transfer people



WEKA BOXCOOLERS

www.fernstrum.com

Phone 906.863.5553 • Fax 906.863.5634 • Export Fax 906.863.5203

E-mail sales@fernstrum.com